

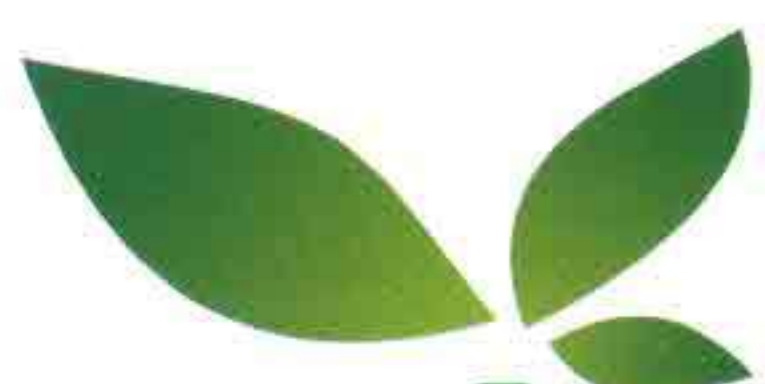

Smart Solutions.  
Strong Relationship.

# Energy Efficient AC Motors

**IE2 Efficiency class**



## Apex Series

a green solution ....



## Crompton Greaves Ltd

As one of the world's leading engineering corporations, CG provides end-to-end solutions, helping its customers to use electrical power effectively and to increase industrial productivity with sustainability. CG was established in 1937 in India; and, since then the company has retained its leadership position in the management and application of electrical energy.

CG is leading manufacturer of electric motors, with motor solutions, which benefits a wide range of customers. Our products are used in almost every industrial application including general manufacturing, petrochemicals, food processing, pharmaceuticals where they drive fans, pumps, compressors, conveyors, lifts and cranes, amongst other things.

Our core competencies lie in our design facility conforming to the international quality standards. We make continuous effort, to bring out the latest, most advanced product into market-place. We continuously add many new services, features and introduce new solutions so as to ensure complete customer satisfaction.

## Apex Series

Apex IE2 series is a green solution by CG to save energy, as growing cost of energy calls for power savings at each possible step of manufacturing. Electric motor driven systems used in industrial process consume about 70% of electricity.

These motors are complying with new efficiency requirements of IEC60034-30:2008 IS12615:2011 standard. Apex aluminium motor range covers ac squirrel cage induction motors with output from 0.75kW to 7.50 kW in frame sizes GD80 TO GD132M. Apex series cast iron range covers ac squirrel cage induction motor with output from 0.75 kW to 250 kW in frame NG80 to ND355LX. They are being used in various range of application from food processing to chemical & heating to refrigeration.

## Quality assurance

Stringent quality procedures are observed from first design to finished product in accordance with the ISO9001 documented quality systems. All of our factories have been assessed to meet these requirements, a further assurance that only the highest possible standards of quality are accepted.

## Benefits of Apex Series Motors

- High efficient at low running cost
- Low vibration and noise
- High torque with smooth acceleration

## Multi Mount

(Aluminium motor range upto 7.5 kW)- By simply changing the position of feet, user is able to convert right, left or top terminal box position and by changing the standard end shield user can change it for flange or face version.

## IEC 60034-30:2008 / IS 12615-2011 Specifications

International Electro technical Commission (IEC) standard IEC 60034-30:2008 defines energy-efficiency (IE code) classes for single speed, three-phase, 50 and 60 Hz induction motors. The efficiency levels defined in IEC 60034-30 are based on test methods specified in IEC 60034-2-1:2007

The standard defines three International energy efficiency classes (IE classes).

- IE1 = Standard efficiency (EFF2 in the former European classification scheme)
- IE2 = High efficiency (EFF1 in the former European classification scheme and equivalent to EPA in the USA for 60 Hz)
- IE3 = Premium efficiency (equivalent to NEMA Premium in USA for 60 Hz)

The standard covers almost all motors (for example standard, marine, brake motors, geared motor)

- Single speed, three-phase, 50 Hz and 60 Hz
- 2, 4 or 6 poles
- Rated output from 0.75 to 375 kW
- Rated voltage up to 1000 V
- Duty type S1 (continuous duty) or S3 (intermittent periodic duty) with a rated cyclic duration factor of 80 percent or higher
- Capable of operating direct online

The following motors are excluded from the standard :

- Motors made solely for converter operation.
- Motors completely integrated into a machine (for example, pump, fan or compressor) that can not be tested separately from the machine.
- Motors rated for duty cycles S4 and above except if an equivalent S1 duty is specified by the driven equipment manufacturer.

## Additional Specifications of IS 12615-2011

The motors are capable of delivering rated output with,

- terminal voltage differing from its rated value by not more than  $\pm 10\%$ , or
- frequency differing from its rated value by not more than  $\pm 5\%$ , or
- the sum of absolute percent variations of (a) & (b) not exceeding 10%

The fixing dimensions and shaft extensions of motors are conforming to the values specified in IS 1231 and IS 2223.

The relationship between output, in kW and frame number are according to IS 1231.

Apart from efficiency, Indian Standard defines following performance parameters for IE2 motors

- 1) Full load Speed
- 2) Full load Current
- 3) Breakaway Torque
- 4) Breakaway Current

## IEC 60034-2-1:2007 / IS 15999 (Part 3 / sec 1) Specification

The standard introduces new rules concerning the testing methods to be used for determining losses and efficiency. It offers two ways of determining efficiency; the direct and indirect methods. The standard specifies the following parameters for determining efficiency using the indirect method:

- 1) Reference temperature
- 2) Four options for determining PLL (additional load losses):
  - a. Measurement- PLL calculated from load tests
  - b. Estimation- PLL at assigned value 2.5% -1.0% of input power at rated load between 0.1 kW and 1000 kW
  - c. Mathematical calculation -  $E_h$  star - alternative indirect method with mathematical calculation of PLL
  - d. PLL from removed rotor and reverse rotation test

Winding losses in stator and rotor are determined at (25°C + actual temperature rise measured)

The resulting efficiency values differ from those obtained under the previous IEC testing standard, IEC 60034-2:1996.

It must be noted that efficiency values are only comparable if they are measured using the same method.

## REFERENCE STANDARDS

Standards	Description
IEC 60034-1:2010	Rotating electrical machines - Rating & Performance
IEC 60034-30:2008	Rotating electrical machines - IE Code for Efficiency Classes
IEC 60034-2-1:2007	Rotating electrical machines - Determination of Losses & Efficiency
IEC 60034-5:2006	Rotating electrical machines - Degrees of protection
IEC 60034-9:2007	Rotating electrical machines - Noise Limits
IEC 60034-14:2007	Rotating electrical machines - Vibration Limits
IEC 60072-1:1991	Rotating electrical machines - Dimensions
IS 1231:1974	Rotating electrical machines - Dimensions foot mounted
IS 2223-1983	Rotating electrical machines - Dimensions flange mounted



# APEX SERIES

# INTRODUCTION

Efficiency values defined in IEC 60034-30:2008 / IS12615-2011

Output kW	IE1 Standard Efficiency			IE2 High Efficiency			IE3 Premium Efficiency		
	2 Pole	4 Pole	6 Pole	2 Pole	4 Pole	6 Pole	2 Pole	4 Pole	6 Pole
0.75	72.1	72.1	70.0	77.4	79.6	75.9	80.7	82.5	78.9
1.1	75.0	75.0	72.9	79.6	81.4	78.1	82.7	84.1	81.0
1.5	77.2	77.2	75.2	81.3	82.8	79.8	84.2	85.3	82.5
2.2	79.7	79.7	77.7	83.2	84.3	81.8	85.9	86.7	84.3
3	81.5	81.5	79.7	84.6	85.5	83.3	87.1	87.7	85.6
4	83.1	83.1	81.4	85.8	86.6	84.6	88.1	88.6	86.8
5.5	84.7	84.7	83.1	87.0	87.7	86.0	89.2	89.6	88.0
7.5	86.0	86.0	84.7	88.1	88.7	87.2	90.1	90.4	89.1
11	87.6	87.6	86.4	89.4	89.8	88.7	91.2	91.4	90.3
15	88.7	88.7	87.7	90.3	90.6	89.7	91.9	92.1	91.2
18.5	89.3	89.3	88.6	90.9	91.2	90.4	92.4	92.6	91.7
22	89.9	89.9	89.2	91.3	91.6	90.9	92.7	93.0	92.2
30	90.7	90.7	90.2	92.0	92.3	91.7	93.3	93.6	92.9
37	91.2	91.2	90.8	92.5	92.7	92.2	93.7	93.9	93.3
45	91.7	91.7	91.4	92.9	93.1	92.7	94.0	94.2	93.7
55	92.1	92.1	91.9	93.2	93.5	93.1	94.3	94.6	94.1
75	92.7	92.7	92.6	93.8	94.0	93.7	94.7	95.0	94.6
90	93.0	93.0	92.9	94.1	94.2	94.0	95.0	95.2	94.9
110	93.3	93.3	93.3	94.3	94.5	94.3	95.2	95.4	95.1
132	93.5	93.5	93.5	94.6	94.7	94.6	95.4	95.6	95.4
160	93.7	93.8	93.8	94.8	94.9	94.8	95.6	95.8	95.6
200	94.0	94.0	94.0	95.0	95.1	95.0	95.8	96.0	95.8
250	94.0	94.0	94.0	95.0	95.1	95.0	95.8	96.0	95.8
315	94.0	94.0	94.0	95.0	95.1	95.0	95.8	96.0	95.8
355	94.0	94.0	94.0	95.0	95.1	95.0	95.8	96.0	95.8
375	94.0	94.0	94.0	95.0	95.1	95.0	95.8	96.0	95.8

**NOTE :-**

- 1) It must be noted that efficiency values are only comparable if they are measured using the same method.
- 2) Any efficiency value between IE1 and IE2 values, is to be considered as IE1 class for motors.
- 3) Any efficiency value between IE2 and IE3 values, is to be considered as IE2 class for motors.
- 4) The full load efficiency of any individual motor, when tested at rated voltage and frequency, shall not be less than the rated efficiency minus the tolerances in accordance with IEC 60034-1.
- 5) Energy efficient cage induction motors are typically built with more active material, i.e. longer core length and/or greater core diameter in order to achieve the higher efficiency. For these reason the starting performance of energy efficient motors differs somewhat from motors with a lower efficiency. On average the locked rotor current increases by 10%-15% for motors from one energy efficiency class compared to motors of the next higher class with the same output power. Individually, this difference depends on the construction principle of the motor and should be checked with manufacturer when replacing motors in a n existing installation. It must be ensured that the control protective device is properly sized and setup.
- 6) As per IEC60034-30 : 2008 motors specially designed,
  - For special requirement of the driven machine (e.g heavy starting duty, special torque stiffness and/or breakdown torque characteristics, large number of start/stop cycles, very low rotor inertia)
  - For special characteristics of grind supply (e.g limited starting current, high tolerances of voltage and/or frequency)
  - For special ambient conditions (e.g very low ambient temperature, smoke extraction motors, high altitudes of installation)
    - may not be able to achieve higher efficiency classifications.

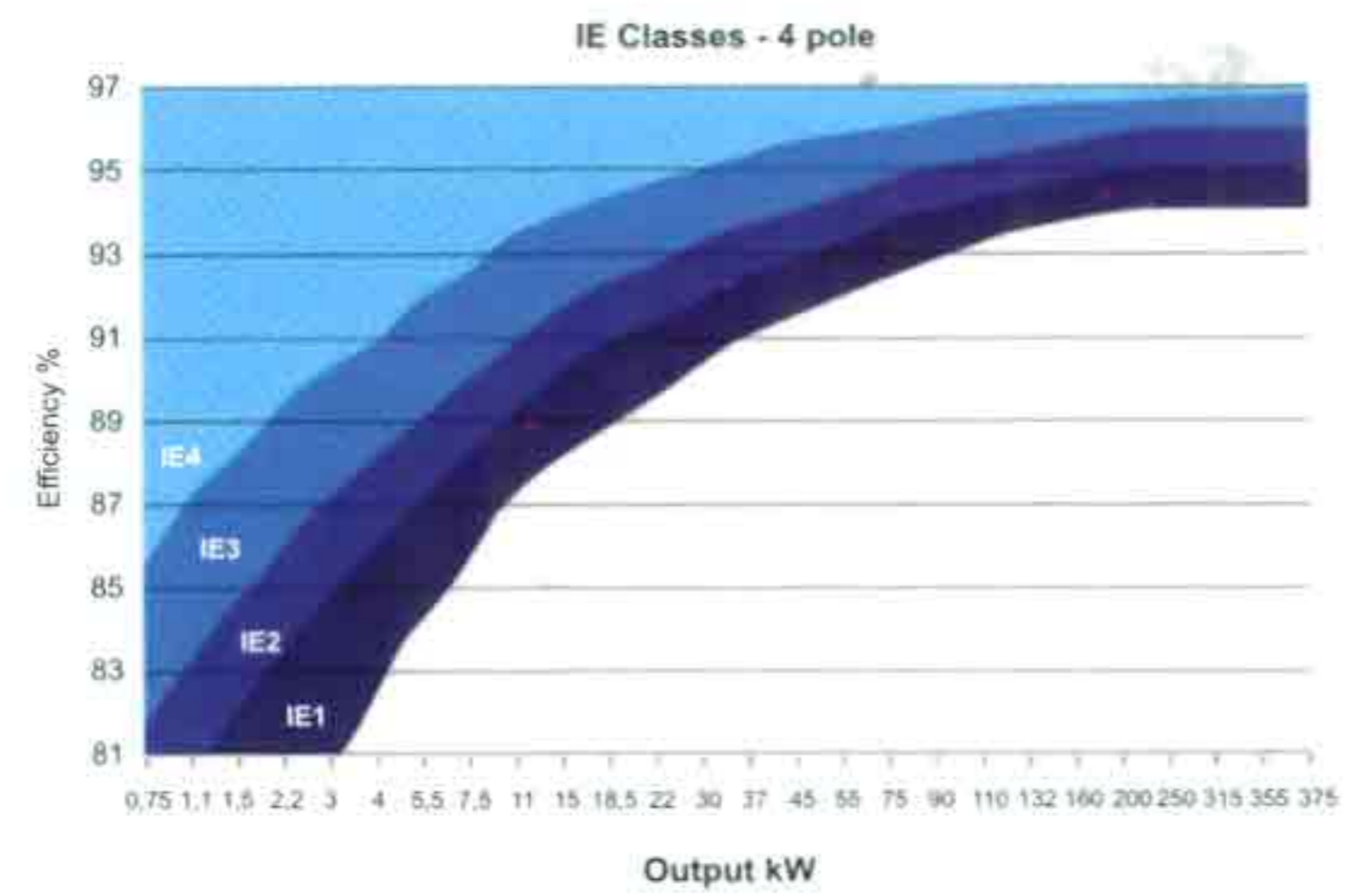



Most electricity today is generated by burning fossil fuels and producing steam which is then used to drive a steam turbine that in turn, drives an electrical generator.

More serious are concerns about the emissions that result from fossil fuel burning. Burning them results in the conversion of carbon to carbon dioxide, which is then released into the atmosphere. The estimated CO<sub>2</sub> emission from the world's electrical power industry is 10 billion tonnes yearly. This results in an increase in the Earth's levels of atmospheric carbon dioxide, which enhances the greenhouse effect and contributes to global warming. The linkage between increased carbon dioxide and global warming is well accepted though fossil-fuel producers vigorously contest these findings.

According to Environment Canada :

Fossil fuel-fired electric power plants emit carbon dioxide, which may contribute to climate change. In addition, the sector has significant impacts on water and habitat and species. In particular, hydro dams and transmission lines have significant effects on water and biodiversity

Here are some more startling predictions of what changes to climate could cause, and how well be affected:

- Major floods may now start to happen every 10 or 20 years rather than once or twice a century
- Global sea levels could rise by almost a meter by 2100
- Exposure to higher levels of UV light could cause an extra 5,000 deaths a year from skin cancer
- Climate change may drive more of a quarter of land animals and plant species to extinction

**Total energy & Feedstock Savings Potentials**

The conclusion is that manufacturing industry can improve its energy efficiency by an impressive 18 to 26%, while reducing the sectors CO<sub>2</sub> emission by 19 to 32%, based on proven technology. Identified improvement options can contribute 7 to 12% reduction in global energy and process-related CO<sub>2</sub> emissions. The single most important category is motor systems, followed by chemicals/petrochemicals on an energy savings basis. The highest range of potential sectoral savings for CO<sub>2</sub> emissions is in cement manufacturing. The savings potential under the heading system/life cycle improvements is larger than the individual sub-sectors in part because those options apply to all industries.

	Low-High Potential		Estimates of Technical Savings		Total Energy & Feedstock Savings Potential
	EJ/yr	Mtoe/Yr	Mt CO <sub>2</sub> /yr		%
Sectoral Improvement					
Chemical / Petrochemicals	5.0-6.5	12-55	370-470		13-16
Iron and steel	2.3-4.5	55-108	220-360		9-18
Cement	2.5-3.0	60-72	480-520		28-33
Pulp and Paper	1.3-1.5	31-36	52-105		15-18
Aluminium	0.3-0.4	7-10	20-30		6-8
Other non-metallic metals					
Minerals and non-ferrous	0.5-1.0	12-24	40-70		13-25
System/life cycle improvement					
Motor System	6-8	143-191	340-750		
Combined head and power stem system	2-3	48-72	110-170		
Process integration	1.5-2.5	36-60	110-180		
Increased recycling	1-2.5	24-60	70-180		
Energy Recovery	1.5-2.3	36-55	80-190		
Total	25-37	600-900	1900-3200		
Global improvement potential-share of industrial energy use and CO <sub>2</sub> emissions	18-26	% 18-26	% 19-32	%	

Reference : Tracking industrial energy efficiency and CO<sub>2</sub> emissions



Conserve Energy for a Brighter Future..!



## Apex series Aluminium motors (GD Frames)

Range	
Output	0.75 kW to 7.50 kW
Frames	GD 80 TO GD 132
Poles	2,4,6

Specification		
	Standard Product	Option
Frame sizes	80 to 132	-
Enclosure	IP55	IP56, IP65
Mounting option	Foot (B3)	Flange (B5), Face (B14) or Pad (B30)
Terminal box position	Top	Left hand side (LHS), Right hand side (RHS)
Voltage	3 kW and below: 415 $\Delta$ / 400 $\Delta$	380 $\Delta$
	3.7 kW and above: 415 $\Delta$ / 400 $\Delta$	380 $\Delta$ Others on request
Frequency	50 Hz	60 Hz
Cooling	IC411	IC410
Lubrication	Frame 80 to 132 double-shielded bearings	-
Insulation	Class F	Class H
Temperature rise	Class B	Class F
Paint color	Gentian blue (RAL 5010)	On request
Fan cover	Steel	Plastic
Thermal protection	-	80 to 132 frames
Anti condensation heaters	-	132 frame
Inverter Duty (with derate)	Variable Torque - 10:1,	
	Constant Torque - 2:1	Alternative speed range
Ambient temperature	- 20°C to + 50°C	Higher than 50°C
DC brake	-	80 to 132 frames
Altitude	$\leq$ 1000m	Higher than 1000 m

The above specification and options give a brief summary of features available for the Apex aluminium range. For a full listing of optional features, please contact CG sales





## Apex series cast Iron motors.(NG,ND Frames)

Range	
Output	0.75 kW to 250 kW
Frames	NG80 to NG132M ND160M to ND355LX
Poles	2,4,6



Specification	Standard Product		Option
	Frame sizes	80 to 355	-
Enclosure	IP55	-	IP56
Mounting option	Foot (B3) mounting feet integral with the Stator body	-	Flange (B5), Face (B14) - upto 132 Frame
Terminal box position	Right hand side (RHS)	-	Top, left hand side (LHS)
Voltage	3 kW and below: 415 $\Delta$ / 400 $\Delta$	-	380 $\Delta$
	3.7 kW and above: 415 $\Delta$ / 690 $\Delta$	-	380 $\Delta$ Others on request
Frequency	50 Hz	-	60 Hz
Cooling	IC411	-	IC410
Lubrication	Frame 80 to 225 double-shielded bearings	-	-
	Frame 250 to 355 online Greasing	-	-
Insulation	Class F	-	Class H
Temperature rise	Class B	-	Class F
Paint colour	Gentian blue (RAL 5010)	-	On request
Fan cover	Steel	-	-
Thermal protection	-	-	80 to 355 frame
Anti condensation heaters	280 to 355 frame	-	132 to 250 frame
	-	-	-
Inverter Duty (with derate)	Variable Torque - 10:1,	-	-
	Constant Torque - 2:1 (for frame 80 to 132)	-	Alternative speed range
Ambient temperature	- 20°C to + 50°C	-	Higher than 50°C; Less than -20°C
DC brake	-	-	80 to 200 frame
Altitude	$\leq$ 1000m	-	Higher than 1000 m

The above specification and options give a brief summary of features available for the Apex cast iron range. For a full listing of optional features, please contact CG sales





## TEFC 3 PHASE FOOT MOUNTED ALUMINIUM INDUCTION MOTORS

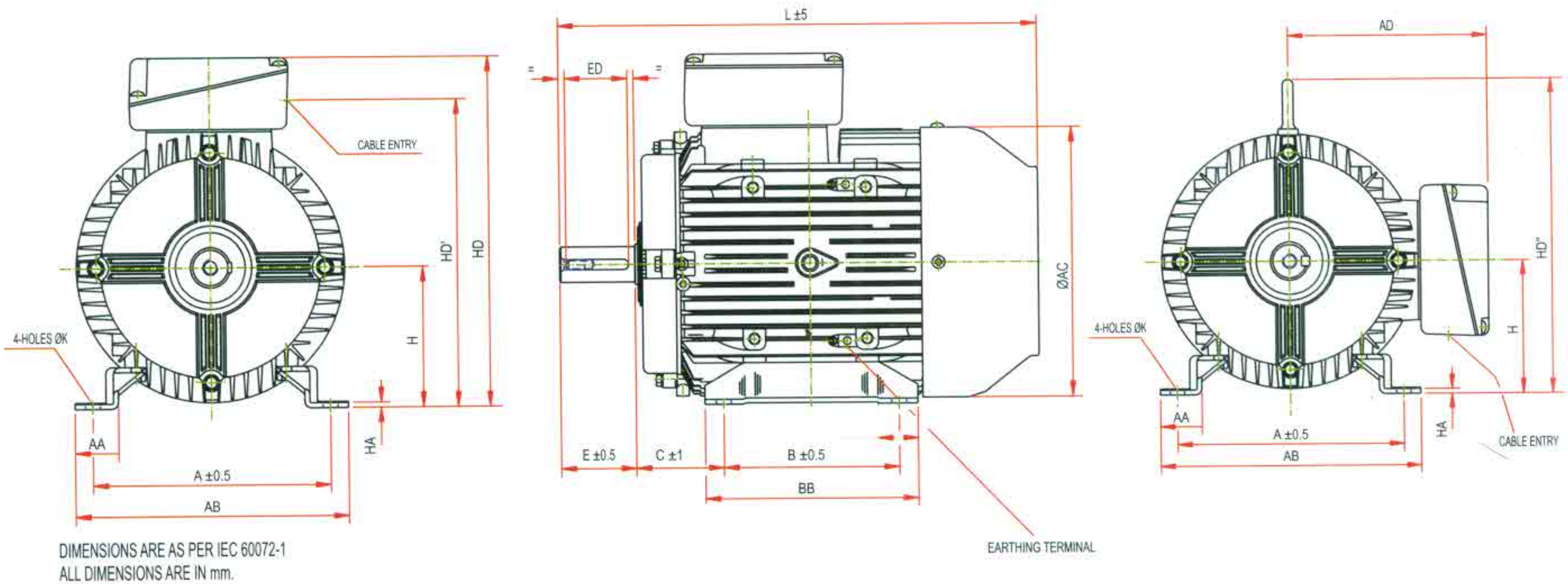

Type	General												Terminal box			
	A	B	C	H	K	L	AA	AB	AC	BB	HA	HD	HD'	TBW	TBH	KK
GD80	125	100	50	80	10	278	27	157	160	127	4	212	183	86	86	20
GD90S	140	100	56	90	10	322	28	164	178	150	4	225	201	86	86	20
GD90L	140	125	56	90	10	322	28	164	178	150	4	225	201	86	86	20
GD100L	160	140	63	100	12	368	28	184	199	170	4	254	223	106	106	20
GD112M	190	140	70	112	12	382	35	218	215	170	4	279	245	127	127	25
GD132S	216	140	89	132	12	451	38	242	255	208	5	320	287	127	127	25
GD132M	216	178	89	132	12	451	38	242	255	208	5	320	287	127	127	25

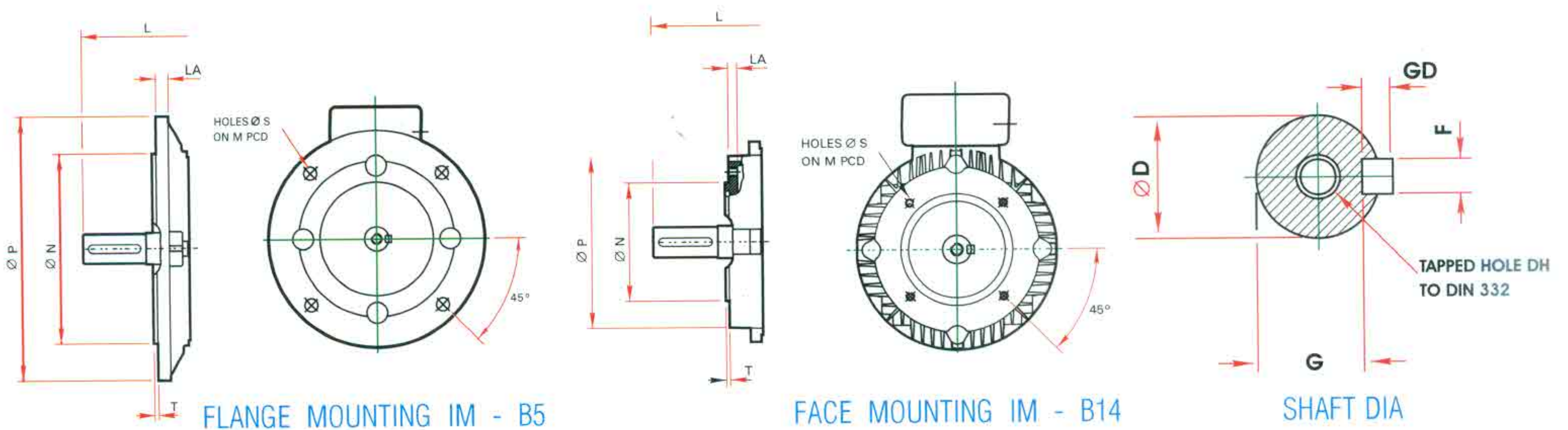

TYPE	IM B5 MOUNTING						IM B14 MOUNTING						SHAFT DIMENSIONS						
	M	N	P	S	T	LA	M	N	P	S	T	LA	TYPE	D	E	F	G	ED	DH
GD80	165	130	200	12	3.5	12	100	80	120	M6	3	9	GD80	19	40	6	15.5	32	M6X16
GD90S/L	165	130	200	12	3.5	10	115	95	140	M8	3	9	GD90S/L	24	50	8	20	40	M8X19
GD100L	215	180	250	14.5	4	12	130	110	160	M8	3.5	12	GD100L	28	60	8	24	50	M10X22
GD112M	215	180	250	14.5	4	12	130	110	164	M8	3.5	13	GD112M	28	60	8	24	50	M10X22
GD132S/M	265	230	300	14.5	4	14	165	130	200	M10	3.5	13	GD132S/M	38	80	10	33	70	M12X28

\* Some features may be different and may not be a part of standard product.



## TEFC, 3 PHASE FOOT MOUNTED CAST IRON INDUCTION MOTORS (NG80 to NG132)

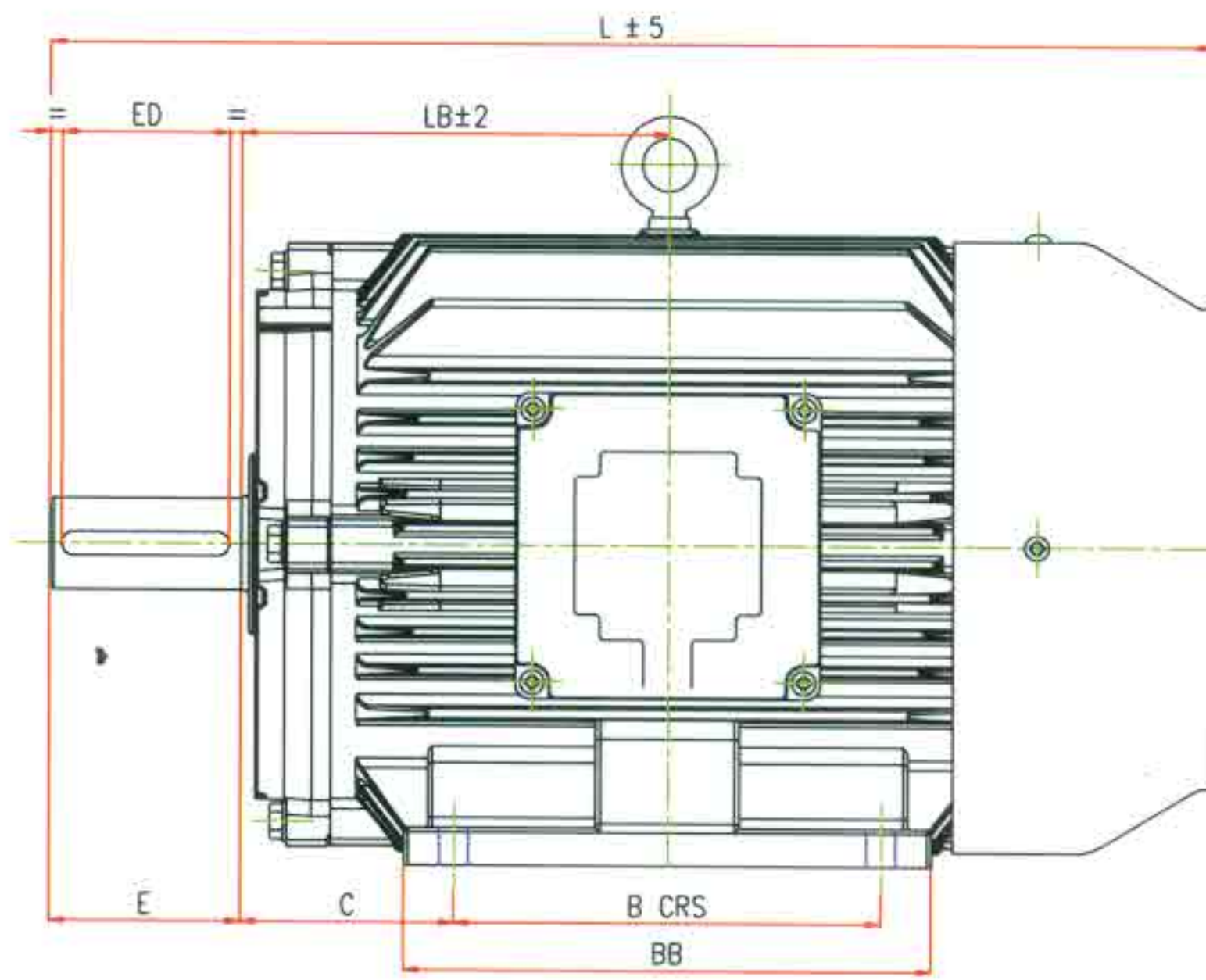
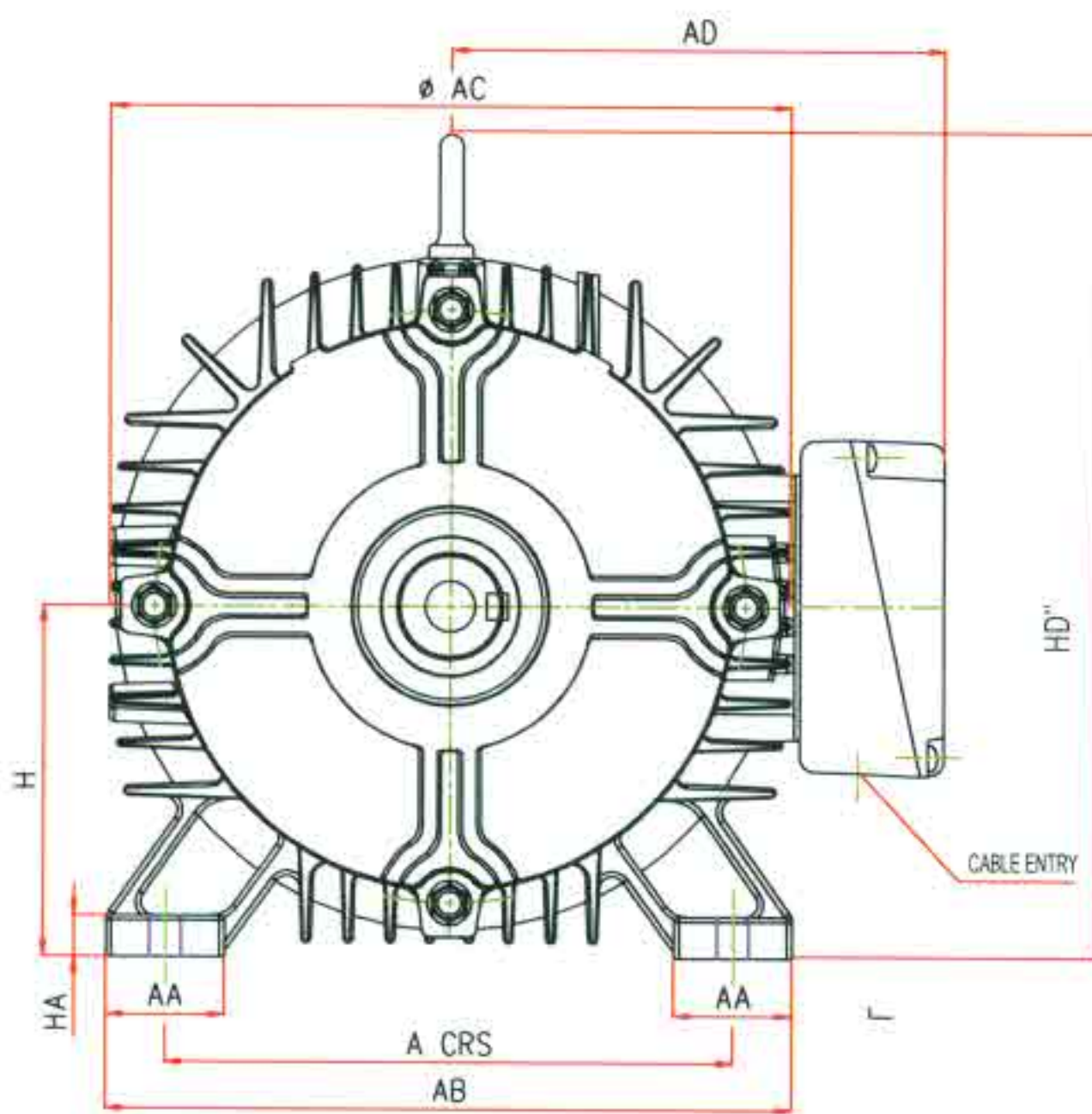

General														Terminal box		
TYPE	A	B	C	H	K	L	AA	AB	AC	AD	BB	HA	HD	TBW	TBH	KK
NG80	125	100	50	80	10	278	35	158	162	127	127	10	-	86	86	1 X 20
NG90S	140	100	56	90	10	322	35	175	180	135	150	12	232	86	86	1 X 20
NG90L	140	125	56	90	10	365	38	175	190	135	195	12	232	86	86	1 X 20
NG100L	160	140	63	100	12	415	34	195	220	170	206	12	262	106	106	1 X 20
NG112M	190	140	70	112	12	445	45	230	230	170	242	12	272	127	127	1 X 25
NG132S	216	140	89	132	12	490	47	255	275	192	220	12	315	127	127	1 X 25
NG132M	216	178	89	132	12	490	47	255	275	192	220	12	315	127	127	1 X 25

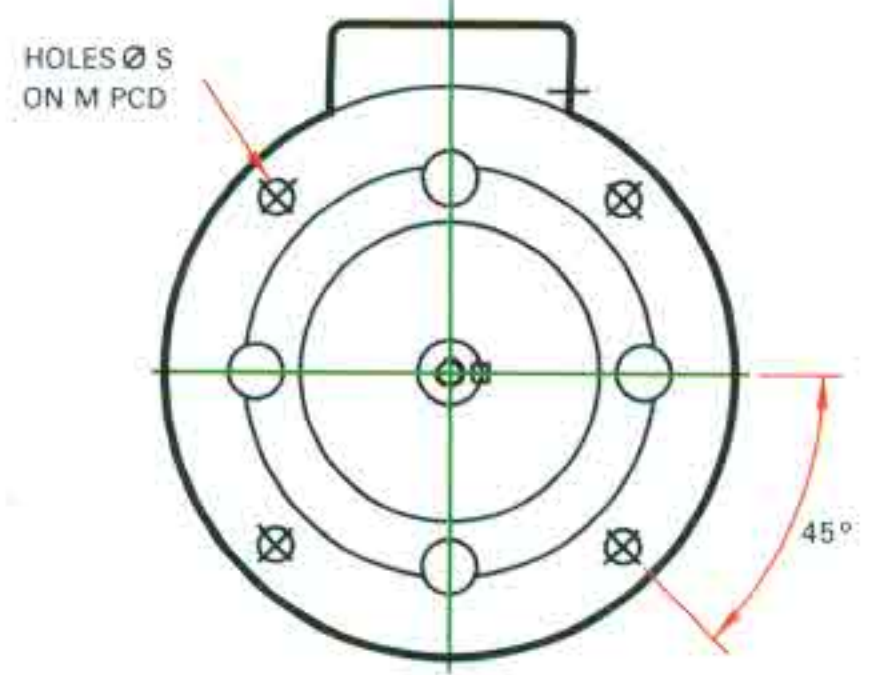
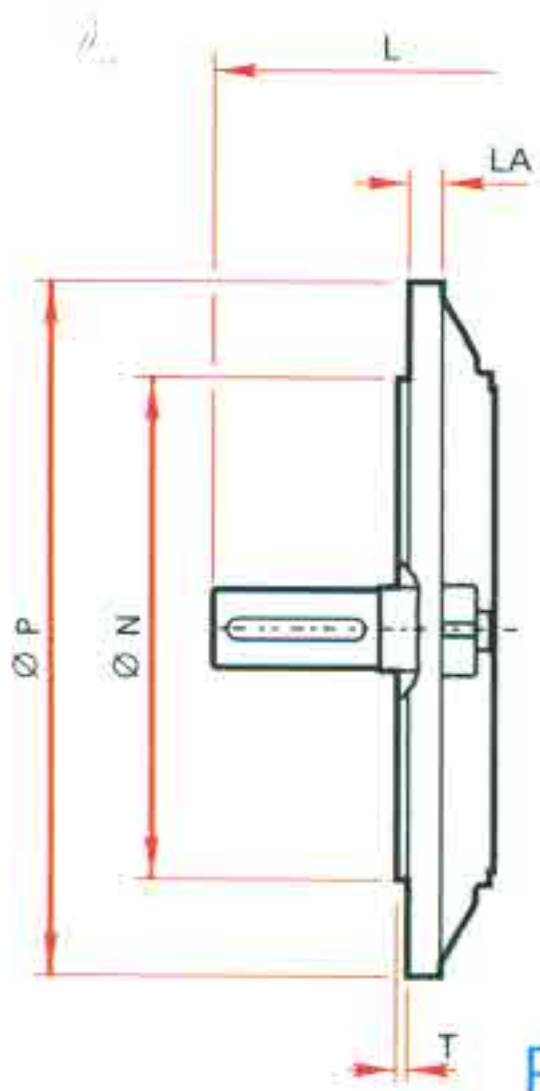

FLANGE MOUNTING IM - B5

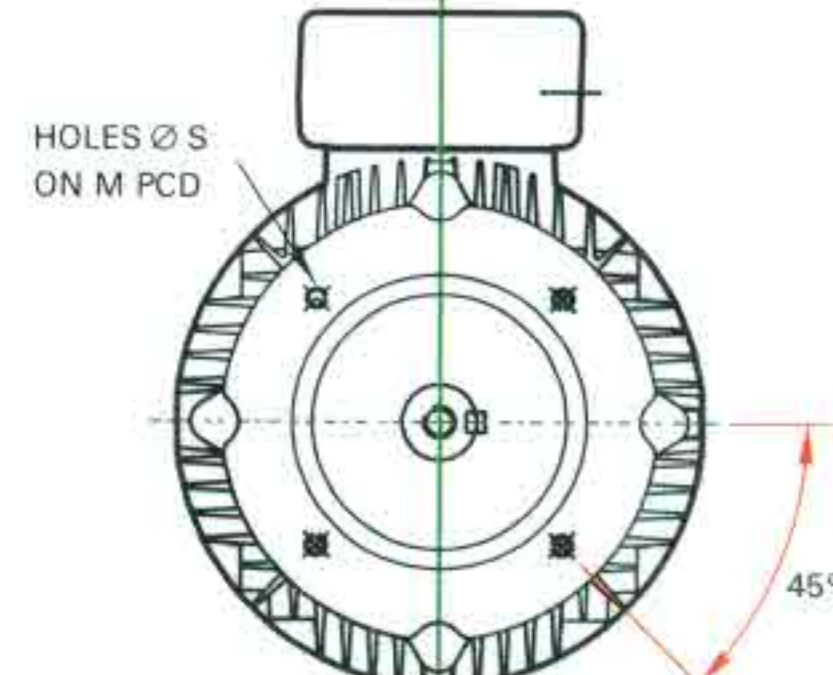
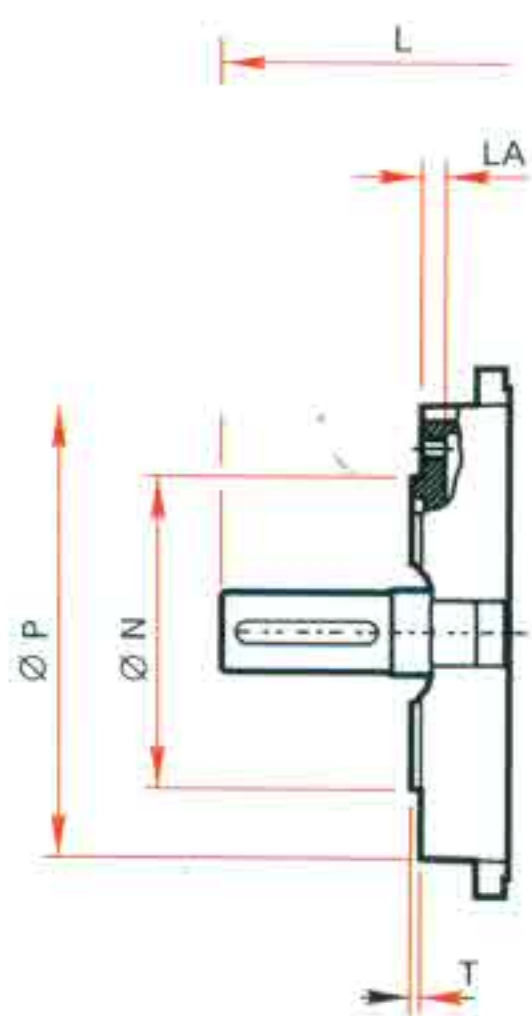

FACE MOUNTING IM - B14

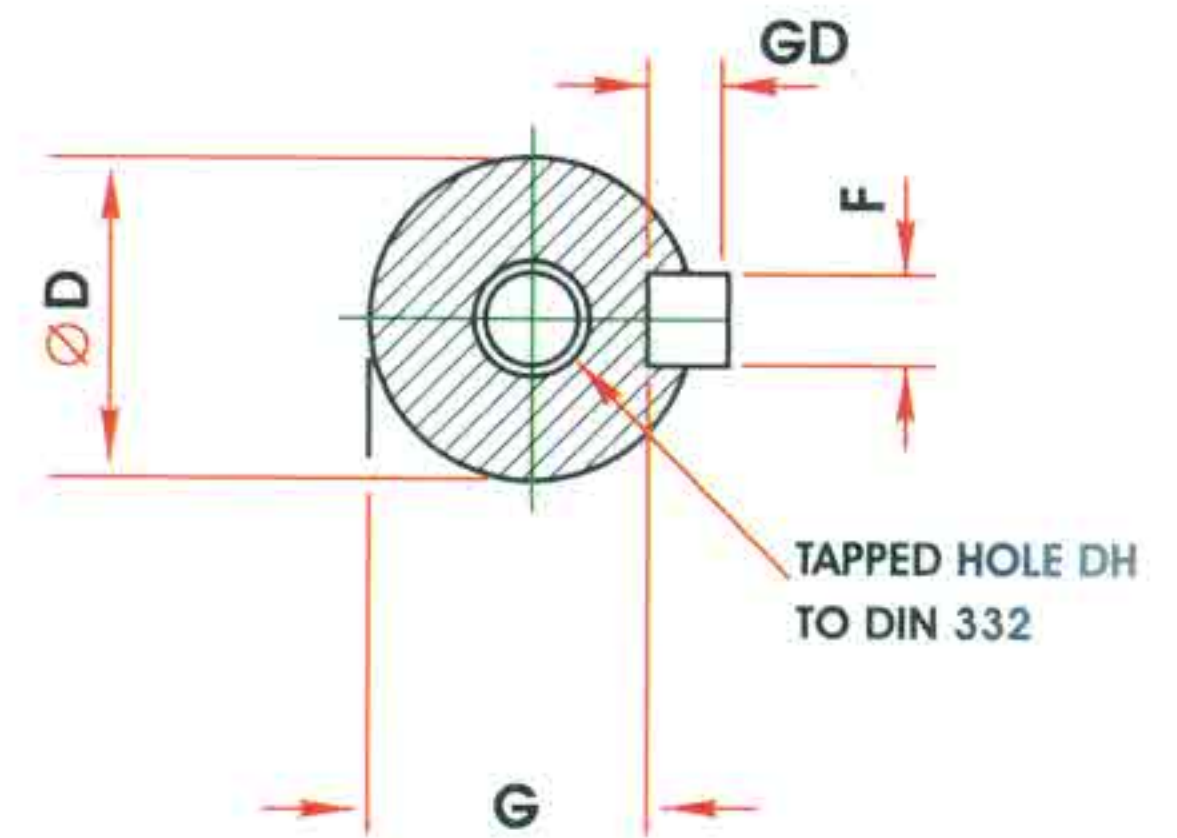

SHAFT DIA

IM B5 MOUNTING							IM B14 MOUNTING						SHAFT DIMENSIONS						
TYPE	M	N	P	S	T	LA	M	N	P	S	T	LA	TYPE	D	E	F	G	ED	DH
NG80	165	130	200	12	3.5	12	100	80	120	M6	3	9	NG80	19	40	6	15.5	32	M6X16
NG90S/L	165	130	200	12	3.5	10	115	95	140	M8	3	9	NG90S/L	24	50	8	20	40	M8X19
NG100L	215	180	250	14.5	4	12	130	110	160	M8	3.5	12	NG100L	28	60	8	24	50	M10X22
NG112M	215	180	250	14.5	4	12	130	110	164	M8	3.5	13	NG112M	28	60	8	24	50	M10X22
NG132S/M	265	230	300	14.5	4	14	165	130	200	M10	3.5	13	NG132S/M	38	80	10	33	70	M12X28

\* Some features may be different and may not be a part of standard product.



## TEFC, 3 PHASE FOOT MOUNTED CAST IRON INDUCTION MOTORS

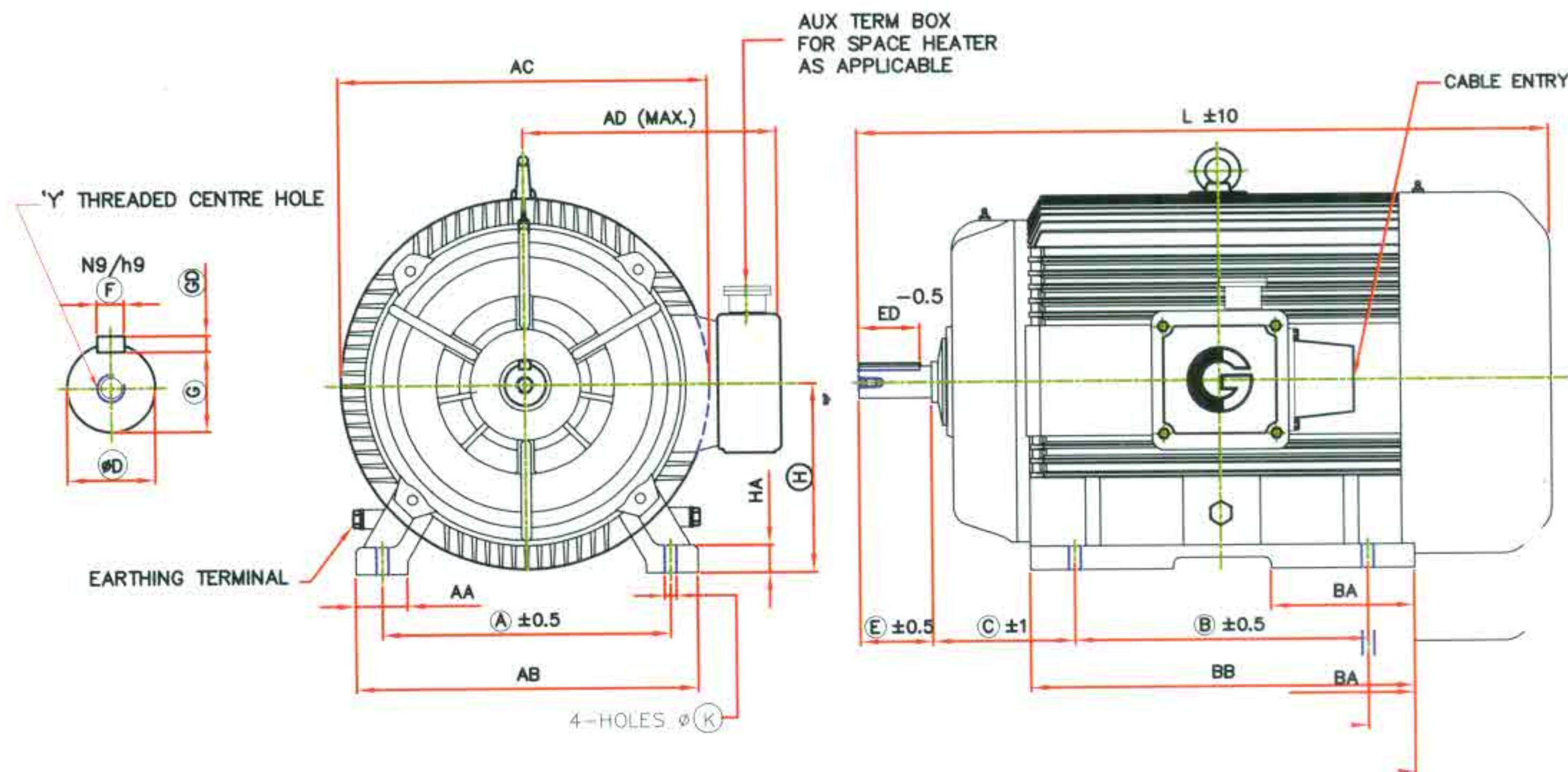

RINGED DIMENSIONS ARE AS PER IEC:60072-1  
ALL DIMENSIONS ARE IN mm

Frame	A	B	C	H	AA	AB	BA	BB	K	D	E	ED	F	GD	G	Y	AD	AC	L	HD	HA
POLE : 2, 4, 6																					
ND160M	254	210	108	160.0 / 159.5	73	308	76	254	15.5 / 15.0	42.018 / 42.002	110	80	12.00 / 11.957	8.00 / 7.91	37.0 / 36.8	M16X32	325	318	605	376	22
ND160L	254	254	108	160.0 / 159.5	73	308	101	298	15.5 / 15.0	42.018 / 42.002	110	80	12.00 / 11.957	8.00 / 7.91	37.0 / 36.8	M16X32	325	318	650	376	22
ND180M	279	241	121	180 / 179.5	84	348	85	286	15.5 / 15.0	48.018 / 48.002	110	80	14.00 / 13.957	9.00 / 8.91	42.5 / 42.3	M16X32	345	352	677	418	22
ND180L	279	279	121	180 / 179.5	84	348	106	323	15.5 / 15.0	48.018 / 48.002	110	80	14.00 / 13.957	9.00 / 8.91	42.5 / 42.3	M16X32	345	352	715	418	22
ND200L	318	305	133	200.0 / 199.5	66	381	115	356	19.5 / 19.0	55.030 / 55.011	110	80	16.00 / 15.957	10.00 / 9.91	49.0 / 48.8	M20X40	430	428	790	480	25
POLE : 4, 6																					
ND225S	356	286	149	225.0 / 224.5	70	425	102	340	19.5 / 19.0	60.030 / 60.011	140	110	18.00 / 17.957	11.00 / 10.91	53.0 / 52.8	M20X40	455	470	840	534	25
ND225M	356	311	149	225.0 / 224.5	70	425	102	375	19.5 / 19.0	60.030 / 60.011	140	110	18.00 / 17.957	11.00 / 10.91	53.0 / 52.8	M20X40	455	470	865	534	25
ND250S	406	311	168	250.0 / 249.5	80	483	140	419	24.5 / 24.0	65.030 / 65.011	140	110	18.00 / 17.957	11.00 / 10.91	58.0 / 57.8	M20X40	485	500	940	598	32
ND250MX	406	349	168	250.0 / 249.5	80	483	140	419	24.5 / 24.0	65.030 / 65.011	140	110	18.00 / 17.957	11.00 / 10.91	58.0 / 57.8	M20X40	485	500	970	598	32
ND280S	457	368	190	280.0 / 279.0	100	538	137	440	24.5 / 24.0	75.030 / 75.011	140	110	20.00 / 19.948	12.00 / 11.91	67.5 / 67.3	M20X40	530	536	1035	642	35
ND280M	457	419	190	280.0 / 279.0	100	538	162	487	24.5 / 24.0	75.030 / 75.011	140	110	20.00 / 19.948	12.00 / 11.91	67.5 / 67.3	M20X40	530	536	1085	642	35
ND315S	508	406	216	315.0 / 314.0	110	597	138	485	28.5 / 28.0	80.030 / 80.011	170	140	22.00 / 21.948	14.00 / 13.91	71.0 / 70.8	M20X40	530	590	1180	725	35
ND315M	508	457	216	315.0 / 314.0	110	597	164	533	28.5 / 28.0	80.030 / 80.011	170	140	22.00 / 21.948	14.00 / 13.91	71.0 / 70.8	M20X40	530	590	1230	725	35
ND315L	508	508	216	315.0 / 314.0	110	610	204	655	28.5 / 28.0	90.035 / 90.013	170	140	25.00 / 24.948	14.00 / 13.91	81.0 / 80.8	M24X50	570	655	1295	755	38
ND315LX	508	508	216	315.0 / 314.0	110	610	235	740	28.5 / 28.0	90.035 / 90.013	170	140	25.00 / 24.948	14.00 / 13.91	81.0 / 80.8	M24X50	570	655	1390	755	38
ND355S	610	510	254	355.0 / 354.0	110	710	253	745	28.5 / 28.0	100.035 / 100.013	210	160	28.00 / 27.948	16.00 / 15.89	90.0 / 89.8	M24X50	560	672	1513	780	40
ND355M	610	560	254	355.0 / 354.0	110	710	253	745	28.5 / 28.0	100.035 / 100.013	210	160	28.00 / 27.948	16.00 / 15.89	90.0 / 89.8	M24X50	560	672	1513	780	40
ND355L	610	630	254	355.0 / 354.0	110	710	253	745	28.5 / 28.0	100.035 / 100.013	210	160	28.00 / 27.948	16.00 / 15.89	90.0 / 89.8	M24X50	560	672	1513	780	40

\* Some features may be different and may not be a part of standard product.



## TEFC, 3 PHASE FOOT MOUNTED CAST IRON INDUCTION MOTORS

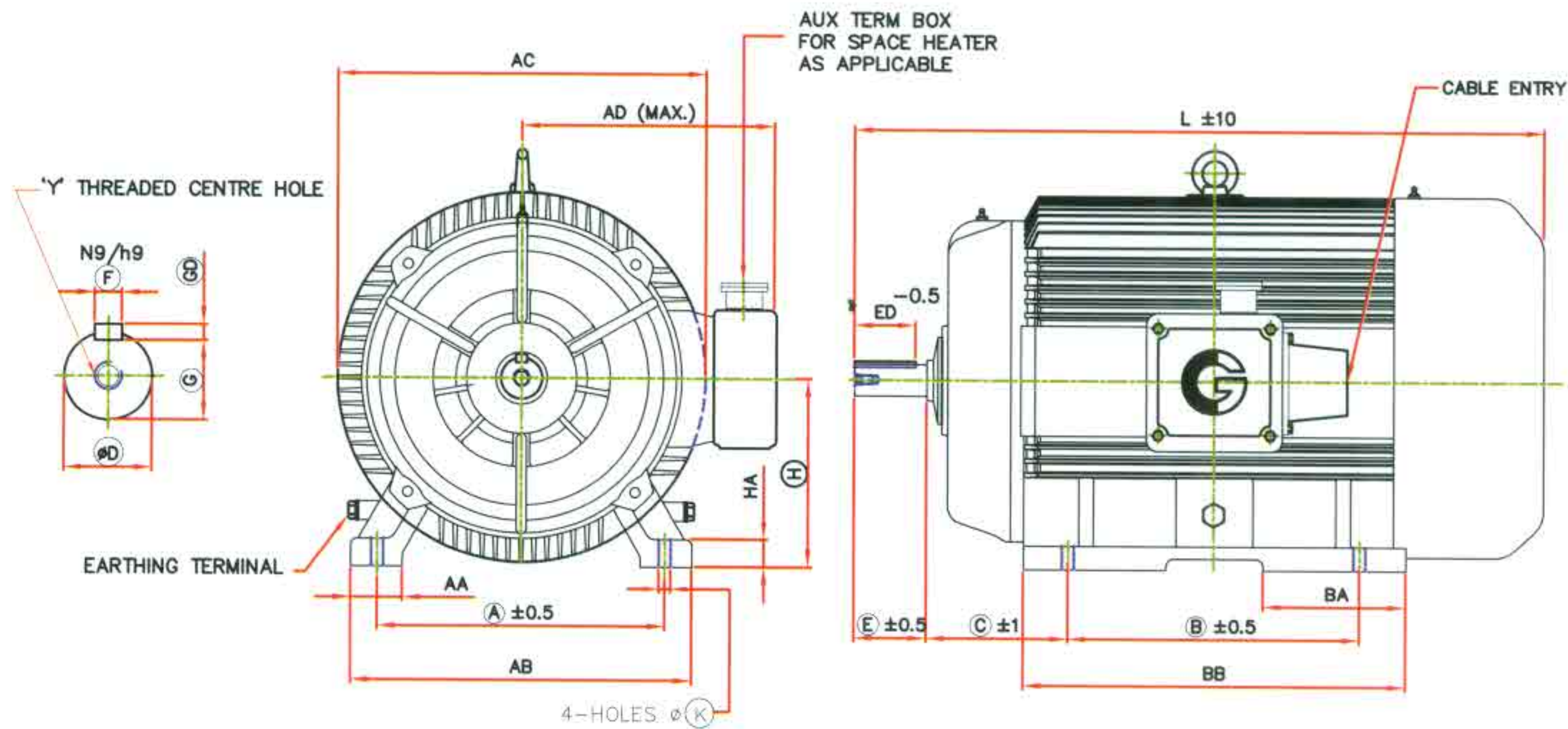

RINGED DIMENSIONS ARE AS PER IEC:60072-1  
ALL DIMENSIONS ARE IN mm.

Frame	A	B	C	H	AA	AB	BA	BB	K	D	E	ED	F	GD	G	Y	AD	AC	L	HD	HA
POLE :2																					
ND225S	356	286	149	225.0 / 224.5	70	425	102	340	19.5 / 19.0	55.030 / 55.011	110	80	16.00 / 15.957	10.00 / 9.91	49.0 / 48.8	M20X40	455	470	810	534	25
ND225M	356	311	149	225.0 / 224.5	70	425	102	375	19.5 / 19.0	55.030 / 55.011	110	80	16.00 / 15.957	10.00 / 9.91	49.0 / 48.8	M20X40	455	470	825	534	25
ND250S	406	311	168	250.0 / 249.5	80	483	140	419	24.5 / 24.0	60.030 / 60.011	140	110	18.00 / 17.957	11.00 / 10.91	53.0 / 52.8	M20X40	485	500	940	598	32
ND250MX	406	349	168	250.0 / 249.5	80	483	140	419	24.5 / 24.0	60.030 / 60.011	140	110	18.00 / 17.957	11.00 / 10.91	53.0 / 52.8	M20X40	485	500	970	598	32
ND280S	457	368	190	280.0 / 279.0	100	538	137	440	24.5 / 24.0	65.030 / 65.011	140	110	18.00 / 17.957	11.00 / 10.91	58.0 / 57.8	M20X40	530	536	1035	642	35
ND280M	457	419	190	280.0 / 279.0	100	538	162	487	24.5 / 24.0	65.030 / 65.011	140	110	18.00 / 17.957	11.00 / 10.91	58.0 / 57.8	M20X40	530	536	1085	642	35
ND315S	508	406	216	315.0 / 314.0	110	597	138	485	28.5 / 28.0	70.030 / 70.011	140	110	20.00 / 19.948	12.00 / 11.91	62.5 / 62.3	M20X40	530	590	1150	725	35
ND315M	508	457	216	315.0 / 314.0	110	597	164	533	28.5 / 28.0	70.030 / 70.011	140	110	20.00 / 19.948	12.00 / 11.91	62.5 / 62.3	M20X40	530	590	1200	725	35
ND315L	508	508	216	315.0 / 314.0	110	610	204	655	28.5 / 28.0	70.030 / 70.011	140	110	20.00 / 19.948	12.00 / 11.91	62.5 / 62.3	M20X40	570	655	1265	755	38
ND315LX	508	508	216	315.0 / 314.0	110	610	235	740	28.5 / 28.0	70.030 / 70.011	140	110	20.00 / 19.948	12.00 / 11.91	62.5 / 62.3	M20X40	570	655	1360	755	38
ND355S	610	510	254	355.0 / 354.0	110	710	253	745	28.5 / 28.0	75.030 / 75.011	170	140	20.00 / 19.948	12.00 / 11.91	67.5 / 67.3	M20X40	560	672	1473	780	40
ND355M	610	560	254	355.0 / 354.0	110	710	253	745	28.5 / 28.0	75.030 / 75.011	170	140	20.00 / 19.948	12.00 / 11.91	67.5 / 67.3	M20X40	560	672	1473	780	40
ND355L	610	630	254	355.0 / 354.0	110	710	253	745	28.5 / 28.0	75.030 / 75.011	170	140	20.00 / 19.948	12.00 / 11.91	67.5 / 67.3	M20X40	560	672	1473	780	40

\* Some features may be different and may not be a part of standard product.



## TEFC, 3 PHASE FOOT MOUNTED CAST IRON INDUCTION MOTORS (FRAME ND355LX)

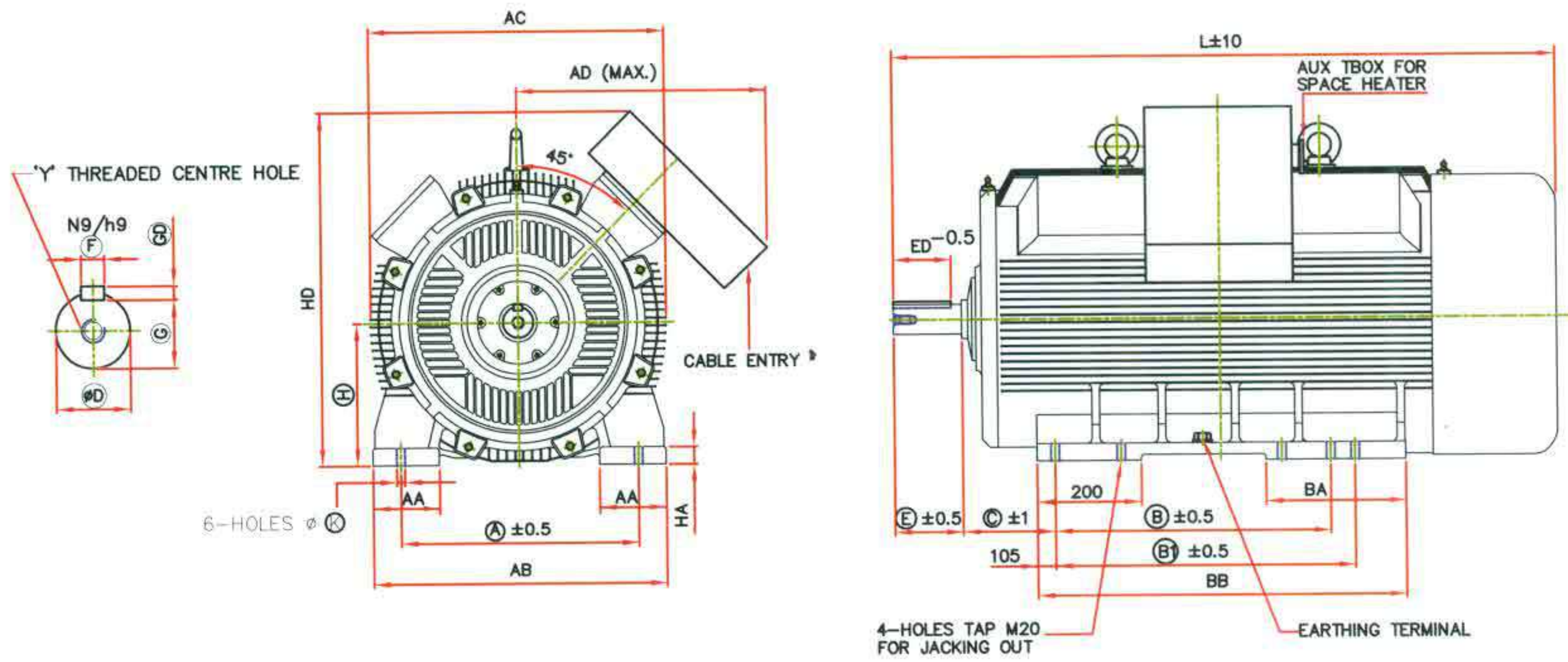

RINGED DIMENSIONS ARE AS PER IEC:60072-1  
ALL DIMENSIONS ARE IN mm

Frame	A	B	C	H	AA	AB	BA	BB	K	D	E	ED	F	GD	G	Y	AD	AC	L	HD	HA
POLE :2																					
ND355LX	610	630	254	355.0 / 354.0	110	710	250	850	28.5 / 28.0	75.030 / 75.011	170	140	20.00 / 19.948	12.00 / 11.91	67.5 / 67.3	M20X40	720	720	1540	950	40
POLE :4,6																					
ND355LX	610	630	254	355.0 / 354.0	110	710	250	850	28.5 / 28.0	100.035 / 100.013	210	160	28.00 / 27.948	16.00 / 15.89	90.0 / 89.8	M24x50	720	720	1580	950	40

\* Some features may be different and may not be a part of standard product.



## TEFC, 3 PHASE FLANGE MOUNTED CAST IRON INDUCTION MOTORS

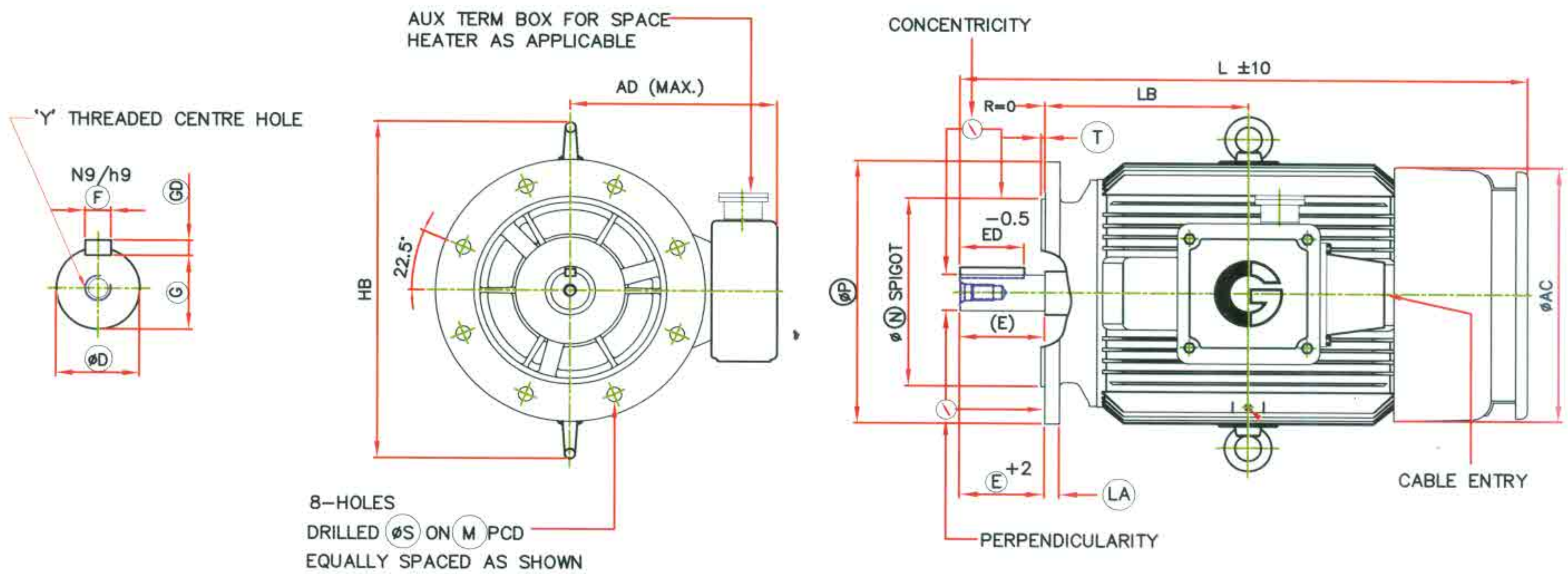

RINGED DIMENSIONS ARE AS PER IEC:60072-1  
ALL DIMENSIONS ARE IN mm

Frame	D	E	ED	F	GD	G	Y	AD	AC	L	MTol	NTol	P	S	T	LA	LB	HB	
<b>POLE : 2,4,6</b>																			
ND160M	42.018 / 42.002	110	80	12.00 / 11.957	8.00 / 7.91	37.0 / 36.8	M16X32	325	318	660	300.5 / 299.5	250.016 / 249.987	350	19	5	18	213	421	
ND160L	42.018 / 42.002	110	80	12.00 / 11.957	8.00 / 7.91	37.0 / 36.8	M16X32	325	318	705	300.5 / 299.5	250.016 / 249.987	350	19	5	18	235	421	
ND180M	48.018 / 48.002	110	80	14.00 / 13.957	9.00 / 8.91	42.5 / 42.3	M16X32	345	352	750	300.5 / 299.5	250.016 / 249.987	350	19	5	18	242	478	
ND180L	48.018 / 48.002	110	80	14.00 / 13.957	9.00 / 8.91	42.5 / 42.3	M16X32	345	352	790	300.5 / 299.5	250.016 / 249.987	350	19	5	18	260	478	
ND200L	55.030 / 55.011	110	80	16.00 / 15.957	10.00 / 9.91	49.0 / 48.8	M20X40	430	428	830	350.5 / 349.5	300.018 / 299.982	400	19	5	18	285	557	
<b>POLE : 4,6</b>																			
ND225S	60.030 / 60.011	140	110	18.00 / 17.957	11.00 / 10.91	53.0 / 52.8	M20X40	455	470	895	400.5 / 399.5	350.018 / 349.982	450	19	5	19	305	618	
ND225M	60.030 / 60.011	140	110	18.00 / 17.957	11.00 / 10.91	53.0 / 52.8	M20X40	455	470	895	400.5 / 399.5	350.018 / 349.982	450	19	5	19	305	618	
ND250S	65.030 / 65.011	140	110	18.00 / 17.957	11.00 / 10.91	58.0 / 57.8	M20X40	485	500	1020	500.5 / 499.5	450.020 / 449.980	550	19	5	22	342	688	
ND250MX	60.030 / 60.011	140	110	18.00 / 17.957	11.00 / 10.91	58.0 / 57.8	M20X40	485	500	1050	500.5 / 499.5	450.020 / 449.980	550	19	5	22	342	688	
ND280S	75.030 / 75.011	140	110	20.00 / 19.948	12.00 / 11.91	67.5 / 67.3	M20X40	530	536	1170	500.5 / 499.5	450.020 / 449.980	550	19	5	22	400	722	
ND280M	75.030 / 75.011	140	110	20.00 / 19.948	12.00 / 11.91	67.5 / 67.3	M20X40	530	536	1170	500.5 / 499.5	450.020 / 449.980	550	19	5	22	400	722	
ND315S	80.030 / 80.011	170	140	22.00 / 21.948	14.00 / 13.91	71.0 / 70.8	M20X40	530	590	1325	601.0 / 599.0	550.022 / 549.978	660	24	6	25	445	812	
ND315M	80.030 / 80.011	170	140	22.00 / 21.948	14.00 / 13.91	71.0 / 70.8	M20X40	530	590	1325	601.0 / 599.0	550.022 / 549.978	660	24	6	25	445	812	
ND315L	90.035 / 90.013	170	140	25.00 / 24.948	14.00 / 13.91	81.0 / 80.8	M24X50	570	655	1495	601.0 / 599.0	550.022 / 549.978	660	24	6	25	531	880	
ND315LX	90.035 / 90.013	170	140	25.00 / 24.948	14.00 / 13.91	81.0 / 80.8	M24X50	570	655	1495	601.0 / 599.0	550.022 / 549.978	660	24	6	25	531	880	
ND355S	100.035 / 100.013	210	160	28.00 / 27.948	16.00 / 15.89	90.0 / 89.8	M24X50	570	672	1650	741.0 / 739.0	680.025 / 679.975	800	24	6	28	570	900	
ND355M	100.035 / 100.013	210	160	28.00 / 27.948	16.00 / 15.89	90.0 / 89.8	M24X50	570	672	1650	741.0 / 739.0	680.025 / 679.975	800	24	6	28	570	900	
ND355L	100.035 / 100.013	210	160	28.00 / 27.948	16.00 / 15.89	90.0 / 89.8	M24X50	570	672	1650	741.0 / 739.0	680.025 / 679.975	800	24	6	28	570	900	

\* Some features may be different and may not be a part of standard product.



## TEFC, 3 PHASE FLANGE MOUNTED CAST IRON INDUCTION MOTORS

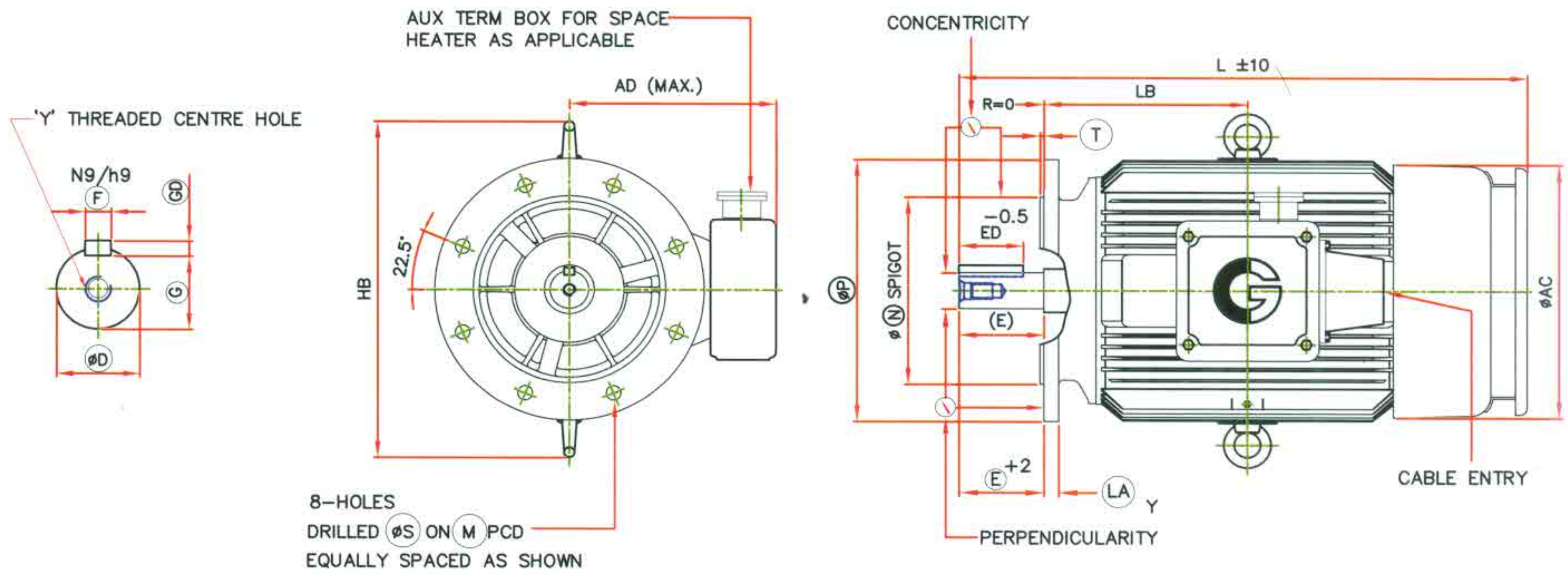

RINGED DIMENSIONS ARE AS PER IEC:60072-1  
ALL DIMENSIONS ARE IN mm

Frame	D	E	ED	F	GD	G	Y	AD	AC	L	MTol	NTol	P	S	T	LA	LB	HB
POLE :2																		
ND225S	55.030 / 55.011	110	80	16.00 / 15.957	10.0 / 9.91	49.0 / 48.8	M20X40	455	470	865	400.5 / 399.5	350.018 / 349.982	450	19	5	19	305	618
ND225M	55.030 / 55.011	110	80	16.00 / 15.957	10.0 / 9.91	49.0 / 48.8	M20X40	455	470	865	400.5 / 399.5	350.018 / 349.982	450	19	5	19	305	618
ND250S	60.030 / 60.011	140	110	18.00 / 17.957	11.00 / 10.91	53.0 / 52.8	M20X40	485	500	1020	500.5 / 499.5	450.020 / 449.980	550	19	5	22	343	688
ND250MX	60.030 / 60.011	140	110	18.00 / 17.957	11.00 / 10.91	53.0 / 52.8	M20X40	485	500	1050	500.5 / 499.5	450.020 / 449.980	550	19	5	22	343	688
ND280S	65.030 / 65.011	140	110	18.00 / 17.957	11.00 / 10.91	58.0 / 57.8	M20X40	530	536	1170	500.5 / 499.5	450.020 / 449.980	550	19	5	22	400	722
ND280M	65.030 / 65.011	140	110	18.00 / 17.957	11.00 / 10.91	58.0 / 57.8	M20X40	530	536	1170	500.5 / 499.5	450.020 / 449.980	550	19	5	22	400	722
ND315S	65.030 / 65.011	140	110	18.00 / 17.957	11.00 / 10.91	58.0 / 57.8	M20X40	530	590	1295	601.0 / 599.0	550.022 / 549.978	660	24	6	25	445	812
ND315M	65.030 / 65.011	140	110	18.00 / 17.957	11.00 / 10.91	58.0 / 57.8	M20X40	530	590	1295	601.0 / 599.0	550.022 / 549.978	660	24	6	25	445	812
ND315L	70.030 / 70.011	140	110	20.00 / 19.948	12.00 / 11.91	62.5 / 62.3	M20X40	570	655	1460	601.0 / 599.0	550.022 / 549.948	660	24	6	25	530	880
ND315LX	70.030 / 70.011	140	110	20.00 / 19.948	12.00 / 11.91	62.5 / 62.3	M20X40	570	655	1460	601.0 / 599.0	550.022 / 549.948	660	24	6	25	530	880
ND355S	75.030 / 75.011	170	140	20.00 / 19.948	12.00 / 11.91	67.5 / 67.3	M20X40	720	720	1610	741.0 / 739.0	680.025 / 679.975	800	24	6	28	570	900
ND355M	75.030 / 75.011	170	140	20.00 / 19.948	12.00 / 11.91	67.5 / 67.3	M20X40	720	720	1610	741.0 / 739.0	680.025 / 679.975	800	24	6	28	570	900
ND355L	75.030 / 75.011	170	140	20.00 / 19.948	12.00 / 11.91	67.5 / 67.3	M20X40	720	720	1610	741.0 / 739.0	680.025 / 679.975	800	24	6	28	570	900

\* Some features may be different and may not be a part of standard product.



## TEFC, 3 PHASE FLANGE MOUNTED CAST IRON INDUCTION MOTORS (FRAME ND355LX)

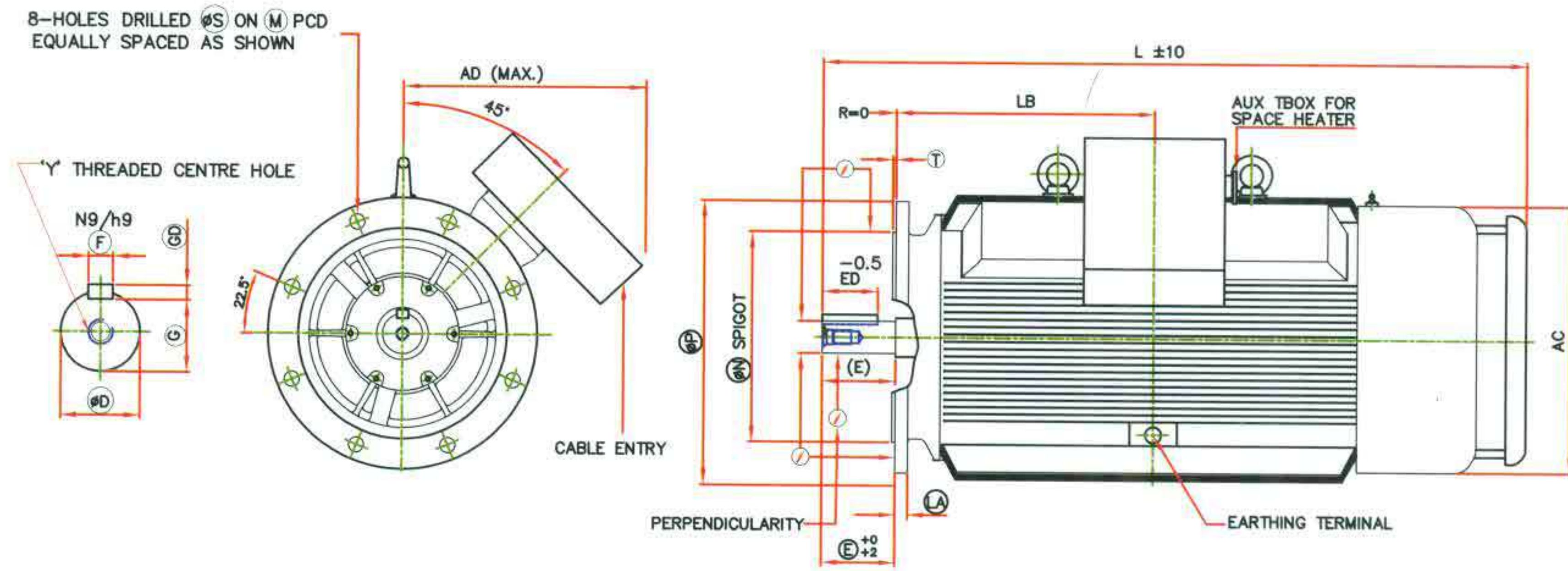

RINGED DIMENSIONS ARE AS PER IEC:60072-1  
ALL DIMENSIONS ARE IN mm

Frame	D	E	ED	F	GD	G	Y	AD	AC	L	MTol	NTol	P	S	T	LA	LB	HB
POLE :2																		
ND355LX	75.030/ 75.011	170	140	20.00/ 19.948	12.00/ 11.91	67.5/ 67.3	M20X40	720	720	1540	741.0/ 739.0	680.025/ 679.975	800	24	6	28	570	900
POLE :4,6																		
ND355LX	100.035/ 100.013	210	160	28.00/ 27.948	16.00/ 15.89	90.0/ 89.8	M24X50	720	720	1580	741.0/ 739.0	680.025/ 679.975	800	24	6	28	570	900

\* Some features may be different and may not be a part of standard product.



## PERFORMANCE DATA FOR ALUMINIUM MOTORS

Efficiency values complying to IE2 class of IEC 60034-30:2008/IS12615:2011

CG PRODUCT CODE	RATED POWER		FRAME	FULL LOAD CURRENT			FL SPEED RPM	FLT Mn kg.m	EFFICIENCY			POWER FACTOR			D.O.L STARTING			PULLOUT POT %FLT	GD <sup>2</sup> kg.m <sup>2</sup>
	kW	hp		380V	400V	415V			FL	3/4L	1/2L	FL	3/4L	1/2L	SSC %FLA	S TT %FLT	POT %FLT		
<b>2 POLE - 3000 Synchronous rpm</b>																			
0.75EG2	0.75	1.00	GD80M	1.69	1.61	1.55	2820	0.3	77.40	76.50	74.00	0.87	0.83	0.77	600	175	225	0.004	
1.10EG2	1.10	1.50	GD80M	2.58	2.45	2.37	2870	0.4	79.60	78.50	77.00	0.81	0.75	0.62	650	250	300	0.007	
1.50EG2	1.50	2.00	GD90S	3.22	3.06	2.95	2840	0.5	81.30	80.50	79.00	0.87	0.82	0.70	650	250	300	0.007	
2.20EG2	2.20	3.00	GD90L	5.02	4.77	4.60	2850	0.8	83.20	82.50	80.50	0.80	0.73	0.65	650	250	300	0.008	
3.00EG2	3.00	4.00	GD100L	6.26	5.95	5.70	2880	1.0	84.60	84.00	82.00	0.86	0.80	0.72	700	250	300	0.031	
3.70EG2	3.70	5.00	GD100L	7.56	7.18	6.90	2880	1.3	85.50	85.00	83.00	0.88	0.83	0.72	700	250	300	0.022	
4.00EG2	4.00	5.50	GD112M	7.96	7.56	7.30	2850	1.4	85.80	85.00	83.00	0.89	0.85	0.78	650	250	300	0.033	
5.50EG2	5.50	7.50	GD132S	10.79	10.25	9.90	2885	1.9	87.00	86.50	85.00	0.89	0.85	0.78	650	250	300	0.076	
7.50EG2	7.50	10.00	GD132S	14.53	13.81	13.30	2885	2.5	88.10	87.50	86.00	0.89	0.85	0.78	650	250	300	0.090	
<b>4 POLE - 1500 Synchronous rpm</b>																			
0.75EG4	0.75	1.00	GD80M	1.85	1.76	1.70	1390	0.5	79.80	79.50	77.00	0.77	0.70	0.56	500	225	275	0.012	
1.10EG4	1.10	1.50	GD90S	2.63	2.50	2.41	1400	0.8	81.40	81.00	79.00	0.78	0.75	0.65	600	225	275	0.017	
1.50EG4	1.50	2.00	GD90L	3.93	3.74	3.60	1435	1.0	82.80	82.50	80.00	0.70	0.60	0.50	600	275	325	0.023	
2.20EG4	2.20	3.00	GD100L	5.02	4.77	4.60	1425	1.5	84.30	83.50	81.00	0.79	0.71	0.57	600	200	275	0.059	
3.00EG4	3.00	4.00	GD100L	7.40	7.03	6.80	1430	2.0	85.50	85.00	83.00	0.72	0.63	0.50	650	225	275	0.065	
3.70EG4	3.70	5.00	GD112M	7.94	7.55	7.30	1430	2.5	86.30	86.00	84.00	0.82	0.76	0.64	600	225	275	0.052	
4.00EG4	4.00	5.50	GD112M	8.35	7.94	7.70	1430	2.7	86.60	86.00	84.00	0.84	0.80	0.70	600	200	275	0.074	
5.50EG4	5.50	7.50	GD132S	12.22	11.61	11.20	1450	3.7	87.70	87.00	85.00	0.78	0.70	0.55	600	225	275	0.138	
7.50EG4	7.50	10.00	GD132M	16.06	15.26	14.70	1450	5.0	88.70	88.00	86.00	0.80	0.73	0.60	600	225	275	0.191	
<b>6 POLE - 1000 Synchronous rpm</b>																			
0.75EG6	0.75	1.00	GD90S	2.21	2.10	2.02	940	0.78	75.90	75.50	74.00	0.68	0.59	0.46	500	200	250	0.017	
1.10EG6	1.10	1.50	GD90L	3.10	2.95	2.84	935	1.15	78.10	77.50	76.00	0.69	0.60	0.47	500	180	250	0.023	
1.50EG6	1.50	2.00	GD100L	4.39	4.17	4.02	940	1.55	79.80	79.50	77.00	0.65	0.59	0.48	500	200	250	0.074	
2.20EG6	2.20	3.00	GD112M	6.19	5.88	5.67	945	2.27	81.80	80.00	78.00	0.66	0.56	0.43	500	180	250	0.069	
3.00EG6	3.00	4.00	GD132S	7.93	7.53	7.30	955	3.06	83.30	83.00	81.50	0.69	0.62	0.50	600	225	275	0.182	
3.70EG6	3.70	5.00	GD132S	9.26	8.80	8.50	950	3.79	84.30	84.00	82.00	0.72	0.65	0.55	650	200	250	0.185	
4.00EG6	4.00	5.50	GD132M	10.41	9.89	9.50	955	4.08	84.60	84.20	82.00	0.69	0.60	0.50	600	200	250	0.208	

\* Output and Frames are as per IS 1231

\* Tolerances are applicable as per IEC 60034-1 : 2010

Full load current indicated are given for respective voltage designs



## PERFORMANCE DATA FOR CAST IRON MOTORS

Efficiency values complying to IE2 class of IEC 60034-30-2008/IS12615:2011

CG PRODUCT CODE	RATED POWER		FRAME	FULL LOAD CURRENT			FL SPEED RPM	FLT M <sub>N</sub> kg.m	EFFICIENCY			POWER FACTOR			D.O.L STARTING			PULLOUT %FLT	GD <sup>2</sup> kg.m <sup>2</sup>
	kW	hp		380V	400V	415V			FL	3/4L	1/2L	FL	3/4L	1/2L	SSC %FLA	S TT %FLT	POT %FLT		
<b>2 Pole - 3000 Synchronous rpm</b>																			
0.75E2	0.75	1.00	NG80M	1.69	1.61	1.55	2820	0.3	77.40	76.50	74.00	0.87	0.83	0.77	600	175	225	0.004	
1.10E2	1.10	1.50	NG80M	2.58	2.45	2.37	2870	0.4	79.60	78.50	77.00	0.81	0.75	0.62	650	250	300	0.007	
1.50E2	1.50	2.00	NG90S	3.22	3.06	2.95	2840	0.5	81.30	80.50	79.00	0.87	0.82	0.70	650	250	300	0.007	
2.20E2	2.20	3.00	NG90L	5.02	4.77	4.60	2850	0.8	83.20	82.50	80.50	0.80	0.73	0.65	650	250	300	0.008	
3.00E2	3.00	4.00	NG100L	6.26	5.95	5.70	2880	1.0	84.60	84.00	82.00	0.86	0.80	0.72	700	250	300	0.031	
3.70E2	3.70	5.00	NG100L	7.56	7.18	6.90	2880	1.3	85.50	85.00	83.00	0.88	0.83	0.72	700	250	300	0.022	
4.00E2	4.00	5.50	NG112M	7.96	7.56	7.30	2850	1.4	85.80	85.00	83.00	0.89	0.85	0.78	650	250	300	0.033	
5.50E2	5.50	7.50	NG132S	10.79	10.25	9.90	2885	1.9	87.00	86.50	85.00	0.89	0.85	0.78	650	250	300	0.076	
7.50E2	7.50	10.00	NG132S	14.53	13.81	13.30	2885	2.5	88.10	87.50	86.00	0.89	0.85	0.78	650	250	300	0.090	
9.3E2	9.30	12.50	ND160M	18	17	17	2930	3.1	88.86	88.86	87.46	0.88	0.85	0.78	700	250	300	0.13	
11E2	11	15	ND160M	21	20	19	2920	4	89.40	89.40	88.00	0.90	0.87	0.84	650	200	250	0.13	
15E2	15	20	ND160M	29	27	26	2925	5	90.30	90.30	89.00	0.88	0.85	0.78	700	200	250	0.17	
18.5E2	18.5	25	ND160L	36	34	33	2920	6	90.90	90.90	89.00	0.90	0.83	0.75	700	250	300	0.21	
22E2	22	30	ND180M	44	41	40	2930	7	91.30	91.30	90.00	0.88	0.82	0.77	600	200	250	0.44	
30E2	30	40	ND200L	57	54	52	2950	10	92.00	92.00	91.00	0.87	0.84	0.78	700	150	225	0.80	
37E2	37	50	ND200L	69	66	63	2950	12	92.50	92.50	91.00	0.84	0.84	0.80	700	150	225	0.89	
45E2	45	60	ND225M	84	79	77	2965	15	92.90	92.90	91.50	0.87	0.85	0.81	700	250	300	1.87	
55E2	55	75	ND250MX	95	91	87	2955	18	93.20	93.20	92.00	0.88	0.92	0.88	700	200	250	2.79	
75E2	75	100	ND280M	135	128	124	2960	25	93.80	93.80	92.00	0.88	0.88	0.85	700	200	250	7.14	
90E2	90	120	ND280M	158	150	145	2975	29	94.10	94.10	93.00	0.94	0.88	0.82	700	250	300	8.18	
110E2	110	150	ND315S	191	181	174	2965	36	94.30	94.30	93.00	0.90	0.89	0.83	700	200	250	6.63	
132E2	132	175	ND315M	228	217	209	2970	43	94.60	94.60	93.50	0.92	0.89	0.83	700	175	225	7.97	
160E2	160	212	ND315L	276	262	252	2975	52	94.80	94.80	93.50	0.93	0.89	0.83	700	175	225	13.90	
180E2	180	241	ND315L	310	295	284	2975	59	94.80	94.80	93.50	0.93	0.89	0.83	700	225	275	13.90	
200E2	200	268	ND315LX	344	327	315	2975	65	95.00	95.00	94.00	0.93	0.89	0.83	700	225	270	16.40	
225E2	225	300	ND355LX	387	368	354	2975	74	95.00	95.00	94.00	0.93	0.89	0.84	700	150	225	18.40	
250E2	250	335	ND355LX	430	408	394	2980	82	95.00	95.00	94.00	0.93	0.89	0.84	700	175	225	27.70	

\* Output and Frames are as per IS 1231

\* Tolerances are applicable as per IEC 60034-1 : 2010

Full load current indicated are given for respective voltage designs



## PERFORMANCE DATA FOR CAST IRON MOTORS

Efficiency values complying to IE2 class of IEC 60034-30-2008/IS12615:2011

CG PRODUCT CODE	RATED POWER		FRAME	FULL LOAD CURRENT			FL SPEED RPM	FLT Mn kg.m	EFFICIENCY			POWER FACTOR			D.O.L STARTING		PULLOUT POT %FLT	GD <sup>2</sup> kg.m <sup>2</sup>
	kW	hp		380V	400V	415V			FL	3/4L	1/2L	FL	3/4L	1/2L	SSC %FLA	S TT %FLT		
0.75E4	0.75	1.00	NG80M	1.85	1.76	1.70	1390	0.5	79.80	79.50	77.00	0.77	0.70	0.56	500	225	275	0.012
1.10E4	1.10	1.50	NG90S	2.63	2.50	2.41	1400	0.8	81.40	81.00	79.00	0.78	0.75	0.65	600	225	275	0.017
1.50E4	1.50	2.00	NG90L	3.93	3.74	3.60	1435	1.0	82.80	82.50	80.00	0.70	0.60	0.50	600	275	325	0.023
2.20E4	2.20	3.00	NG100L	5.02	4.77	4.60	1425	1.5	84.30	83.50	81.00	0.79	0.71	0.57	600	200	275	0.059
3.00E4	3.00	4.00	NG100L	7.40	7.03	6.80	1430	2.0	85.50	85.00	83.00	0.72	0.63	0.50	650	225	275	0.065
3.70E4	3.70	5.00	NG112M	7.94	7.55	7.30	1430	2.5	86.30	86.00	84.00	0.82	0.76	0.64	600	225	275	0.052
4.00E4	4.00	5.50	NG112M	8.35	7.94	7.70	1430	2.7	86.60	86.00	84.00	0.84	0.80	0.70	600	200	275	0.074
5.50E4	5.50	7.50	NG132S	12.22	11.61	11.20	1450	3.7	87.70	87.00	85.00	0.78	0.70	0.55	600	225	275	0.138
7.50E4	7.50	10.00	NG132M	16.06	15.26	14.70	1450	5.0	88.70	88.00	86.00	0.80	0.73	0.60	600	225	275	0.191
9.3E4	9.30	12.50	ND160M	19	18	17	1470	6.2	89.39	89.39	88.09	0.85	0.81	0.70	600	225	275	0.31
11E4	11	15	ND160M	24	23	22	1460	7	89.80	89.80	88.50	0.78	0.73	0.55	550	200	250	0.36
15E4	15	20	ND160L	29	28	27	1465	10	90.60	90.60	89.50	0.86	0.81	0.60	650	250	275	0.47
18.5E4	18.5	25	ND180M	37	35	34	1475	12	91.20	91.20	90.50	0.83	0.79	0.70	600	175	225	0.81
22E4	22	30	ND180L	42	40	39	1470	15	91.60	91.60	91.00	0.86	0.83	0.63	550	175	225	0.95
30E4	30	40	ND200L	59	56	54	1480	20	92.30	92.30	92.00	0.84	0.82	0.71	550	150	225	1.62
37E4	37	50	ND225S	77	73	70	1470	25	92.70	92.70	92.00	0.79	0.75	0.69	600	200	250	2.64
45E4	45	60	ND225M	88	84	81	1475	30	93.10	93.10	92.00	0.83	0.80	0.75	600	200	250	3.13
55E4	55	75	ND250MX	106	101	97	1480	36	93.50	93.50	93.00	0.84	0.79	0.72	700	225	275	3.45
75E4	75	100	ND280S	138	131	126	1480	49	94.00	94.00	92.50	0.88	0.86	0.81	700	225	275	7.21
90E4	90	120	ND280M	165	157	151	1480	59	94.20	94.20	93.00	0.88	0.83	0.75	700	175	225	8.26
110E4	110	150	ND315S	197	187	180	1485	72	94.50	94.50	93.00	0.90	0.85	0.78	650	200	250	11.62
132E4	132	175	ND315M	235	224	215	1485	87	94.70	94.70	93.00	0.90	0.85	0.78	700	225	275	13.98
160E4	160	212	ND315L	285	270	261	1488	105	94.90	94.90	93.50	0.90	0.85	0.78	650	200	250	24.97
180E4	180	241	ND315L	320	304	293	1488	118	94.90	94.90	93.50	0.90	0.85	0.78	650	200	250	24.97
200E4	200	268	ND315LX	355	337	325	1488	131	95.10	95.10	93.50	0.90	0.85	0.78	650	200	250	25.00
225E4	225	300	ND355LX	399	379	366	1490	147	95.10	95.10	94.00	0.90	0.85	0.78	650	150	225	28.00
250E4	250	335	ND355LX	444	422	406	1490	163	95.10	95.10	94.00	0.90	0.85	0.78	650	150	225	29.60

\* Output and Frames are as per IS 1231

\* Tolerances are applicable as per IEC 60034-1 : 2010

Full load current indicated are given for respective voltage designs



## PERFORMANCE DATA FOR CAST IRON MOTORS

Efficiency values complying to IE2 class of IEC 60034-30-2008/IS12615:2011

CG PRODUCT CODE	RATED POWER		FRAME	FULL LOAD CURRENT			FL SPEED RPM	FLT Mn kg.m	EFFICIENCY			POWER FACTOR			D.O.L STARTING		PULLOUT POT %FLT	GD <sup>2</sup> kg.m <sup>2</sup>
	kW	hp		380V	400V	415V			FL	3/4L	1/2L	FL	3/4L	1/2L	SSC %FLA	STT %FLT		
0.75E6	0.75	1.00	NG90S	2.21	2.10	2.02	940	0.78	75.90	75.50	74.00	0.68	0.59	0.46	500	200	250	0.017
1.10E6	1.10	1.50	NG90L	3.10	2.95	2.84	935	1.15	78.10	77.50	76.00	0.69	0.60	0.47	500	180	250	0.023
1.50E6	1.50	2.00	NG100L	4.39	4.17	4.02	940	1.55	79.80	79.50	77.00	0.65	0.59	0.48	500	200	250	0.074
2.20E6	2.20	3.00	NG112M	6.19	5.88	5.67	945	2.27	81.80	80.00	78.00	0.66	0.56	0.43	500	180	250	0.069
3.00E6	3.00	4.00	NG132S	7.93	7.53	7.30	955	3.06	83.30	83.00	81.50	0.69	0.62	0.50	600	225	275	0.182
3.70E6	3.70	5.00	NG132S	9.26	8.80	8.50	950	3.79	84.30	84.00	82.00	0.72	0.65	0.55	650	200	250	0.185
4.00E6	4.00	5.50	NG132M	10.41	9.89	9.50	955	4.08	84.60	84.20	82.00	0.69	0.60	0.50	600	200	250	0.208
5.50E6	5.50	7.50	ND160M	12	11	11	975	5.5	86.00	86.00	84.00	0.84	0.80	0.73	550	175	225	0.40
7.50E6	7.50	10.00	ND160M	16	15	14	975	7.5	87.20	87.20	85.00	0.83	0.79	0.71	600	175	225	0.46
9.3E6	9.30	12.50	ND160M	20	19	18	970	9.3	88.06	88.06	85.56	0.80	0.75	0.65	500	175	225	0.59
11E6	11	15	ND160L	24	23	22	975	11	88.70	88.50	86.00	0.78	0.70	0.56	600	200	250	0.64
15E6	15	20	ND180L	31	30	29	975	15	89.70	89.70	87.00	0.81	0.77	0.69	700	225	275	1.16
18.5E6	18.5	25	ND200L	37	35	33	975	18	90.40	90.40	89.00	0.85	0.81	0.73	600	200	250	1.69
22E6	22	30	ND200L	44	42	41	975	22	90.90	90.90	90.00	0.83	0.78	0.68	600	200	250	2.04
30E6	30	40	ND225M	58	56	54	980	30	91.70	91.70	91.28	0.85	0.81	0.73	600	200	250	3.61
37E6	37	50	ND250MX	73	69	66	980	37	92.20	92.20	91.50	0.84	0.80	0.72	600	200	250	4.82
45E6	45	60	ND280S	87	82	79	985	44	92.70	92.70	90.50	0.85	0.81	0.73	700	225	275	8.01
55E6	55	75	ND280M	109	104	100	980	55	93.10	93.10	91.00	0.82	0.78	0.71	700	200	250	9.89
75E6	75	100	ND315S	147	139	134	985	74	93.70	93.70	92.00	0.83	0.78	0.72	600	200	250	14.12
90E6	90	120	ND315M	173	165	159	985	89	94.00	94.00	92.50	0.84	0.80	0.74	600	200	250	17.00
110E6	110	150	ND315M	209	198	191	985	109	94.30	94.30	93.00	0.85	0.81	0.74	600	200	250	18.98
132E6	132	175	ND315LX	247	234	226	985	130	94.60	94.60	93.00	0.86	0.82	0.74	600	200	250	29.85
160E6	160	212	ND315LX	298	283	273	987	158	94.80	94.80	93.50	0.86	0.82	0.74	600	200	250	29.85
180E6	180	240	ND355LX	339	322	310	988	177	95.00	95.00	93.50	0.85	0.80	0.72	600	200	250	29.90

\* Output and Frames are as per IS 1231

\* Tolerance are applicable as per IEC 60034-1:2010

Full load current indicated are given for respective voltage designs

NOTE : As the design and manufacture of Crompton Greaves electrical equipment are subject to constant improvement, the product supplied may differ in some details from the specifications and illustrations given in this booklet.

For more details, contact CG Sales.



## Bearing Details



Bearings			
Frame	Pole	Driving End	Non-Driving End

### ALUMINIUM MOTORS

GD80	ALL	6204ZZ	6003ZZ
GD90	ALL	6205ZZ	6203ZZ
GD100	ALL	6206ZZ	6205ZZ
GD112	ALL	6206ZZ	6205ZZ
GD132	ALL	6208ZZ	6305ZZ

### CAST IRON MOTORS

NG80	ALL	6204ZZ	6003ZZ
NG90	ALL	6205ZZ	6203ZZ
NG100L	ALL	6206ZZ	6205ZZ
NG112	ALL	6206ZZ	6205ZZ
NG132	ALL	6308ZZ	6305ZZ
ND160	ALL	6309ZZ	6209ZZ
ND180	ALL	6310ZZ	6210ZZ
ND200	ALL	6312ZZ	6212ZZ
ND225	ALL	6313ZZ	6213ZZ
ND250	ALL	6314	6314
ND280	2	6314	6314
ND280	4&UP	6318	6318
ND315	2	6315	6315
ND315	4&UP	6319	6319
ND355	2	6316	6316
ND355L	4&UP	6321	6321
ND355LX	4&UP	6322	6322

## Approximate shipping dimensions & Weights

FRAME	kg	
	NET WT	GR WT
<b>ALUMINIUM</b>		
GD80	9	10
GD90S	13	14
GD90L	15	16
GD100L	27	29
GD112M	33	36
GD132S	54	56
GD132M	54	56
<b>CAST IRON</b>		
NG80	17	21
NG90S	22	26
NG90L	25	29
NG100L	32	37
NG112M	35	40
NG132M	79	89
ND160M	121	151
ND160L	143	173
ND180M	174	208
ND180L	204	238
ND200L	254	291
ND225S	350	430
ND225M	380	460
ND250M	500	575
ND280S	620	761
ND280M	700	841
ND315S	900	1020
ND315M	950	1070
ND315L	1200	1480
ND355L	1500	1800
ND355LX	2020	2425

### Packing case details

Packing case		
Frame	L X B X H	Packing case type
80	360X225X240	Carton
90	390X220X260	Carton
100	460X320X285	Carton
112	460X320X285	Carton
132	485X350X320	Carton
160	800X585X615	Metallic
180	900X685X640	Metallic
200	1000X775X665	Metallic
225	1050X800X725	Metallic
250	1150X925X850	Metallic
280	1250X975X890	Metallic
315	1620X1170X1030	Metallic
355	1870X1345X1180	Metallic

NOTE: - Insulated bearing and Rollers bearings for frame 200 & above are available on request



## Noise Limits (IEC 60034-9) - 2007

Maximum A-weighted sound power level, lwa in dB, at no-load  
(For single speed three-phase cage induction motor IC4111)

Shaft height.			
H mm	2 pole	4 pole	6 pole
90	78	66	63
100	82	70	64
112	83	72	70
132	85	75	73
160	87	77	73
180	88	80	77
200	90	83	80
225	92	84	80
250	92	85	82
280	94	88	85
315	98	94	89
355	100	95	94

## MOUNTING ARRANGMENTS (IEC 60034-7)

HORIZONTAL			VERTICAL		
FIGURE			FIGURE		
REF	B3	B5	REF	V1	V5
FRAME	WITH FEET	WITHOUT FEET	FRAME	WITHOUT FEET	WITH FEET
SHAFT	HORIZONTAL	HORIZONTAL	SHAFT	FACE VERT. DOWN	FACE VERT. DOWN
MTNG	BASE OR RAILS	FLANGE TYPE D	MTNG	FLANGE TYPE D	BASE OR RAILS
FIGURE			FIGURE		
REF	B35	B14	REF	V15	V3
FRAME	WITH FEET & FLANGE	WITHOUT FEET	FRAME	WITH FEET	WITHOUT FEET
SHAFT	HORIZONTAL	HORIZONTAL	SHAFT	FACE VERT. DOWN	FACE VERT. UP
MTNG	BASE OR FLANGE TYPE D	FLANGE TYPE C	MTNG	WALL OR FLANGE TYPE D	FLANGE TYPE D
FIGURE			FIGURE		
REF	B34	B6	REF	V36	V6
FRAME	WITH FEET	WITH FEET	FRAME	WITH FEET	WITH FEET
SHAFT	HORIZONTAL	HORIZONTAL	SHAFT	FACE VERT. UP	FACE VERT. UP
MTNG	BASE OR FLANGE TYPE C	WALL	MTNG	WALL OR FLANGE TYPE D	BASE OR RAILS
FIGURE			FIGURE		
REF	B7	B8	REF	V18	V19
FRAME	WITH FEET	WITH FEET	FRAME	WITHOUT FEET	WITHOUT FEET
SHAFT	HORIZONTAL	HORIZONTAL	SHAFT	FACE VERT. DOWN	FACE VERT. UP
MTNG	WALL	CEILING	MTNG	FLANGE TYPE C	FLANGE TYPE C

\* For installation of foot mounted motor on the wall, additional support must be provided.  
These mountings are shown for information purpose only, for availability please contact CG sales.



## FREQUENTLY ASKED QUESTIONS

### 1. What is IE?

IE is International Efficiency with class 1, 2 & 3 i.e. IE1, IE2 & IE3. The new standard IEC 60034-30:2008/IS12615:2011 defines these classes. At the same time, with the IEC 60034-2-1:2007/IS12615:2011 standard, a new procedure for the determination of efficiency has been introduced which also contributes to international harmonization.

This standard is made to unify motor testing procedures, determination of efficiency and product labeling requirements. This is to enable motor user worldwide to easily identify premium efficiency products. New efficiency classes defined by IEC60034-30 and its equivalence with other standards/nomenclature

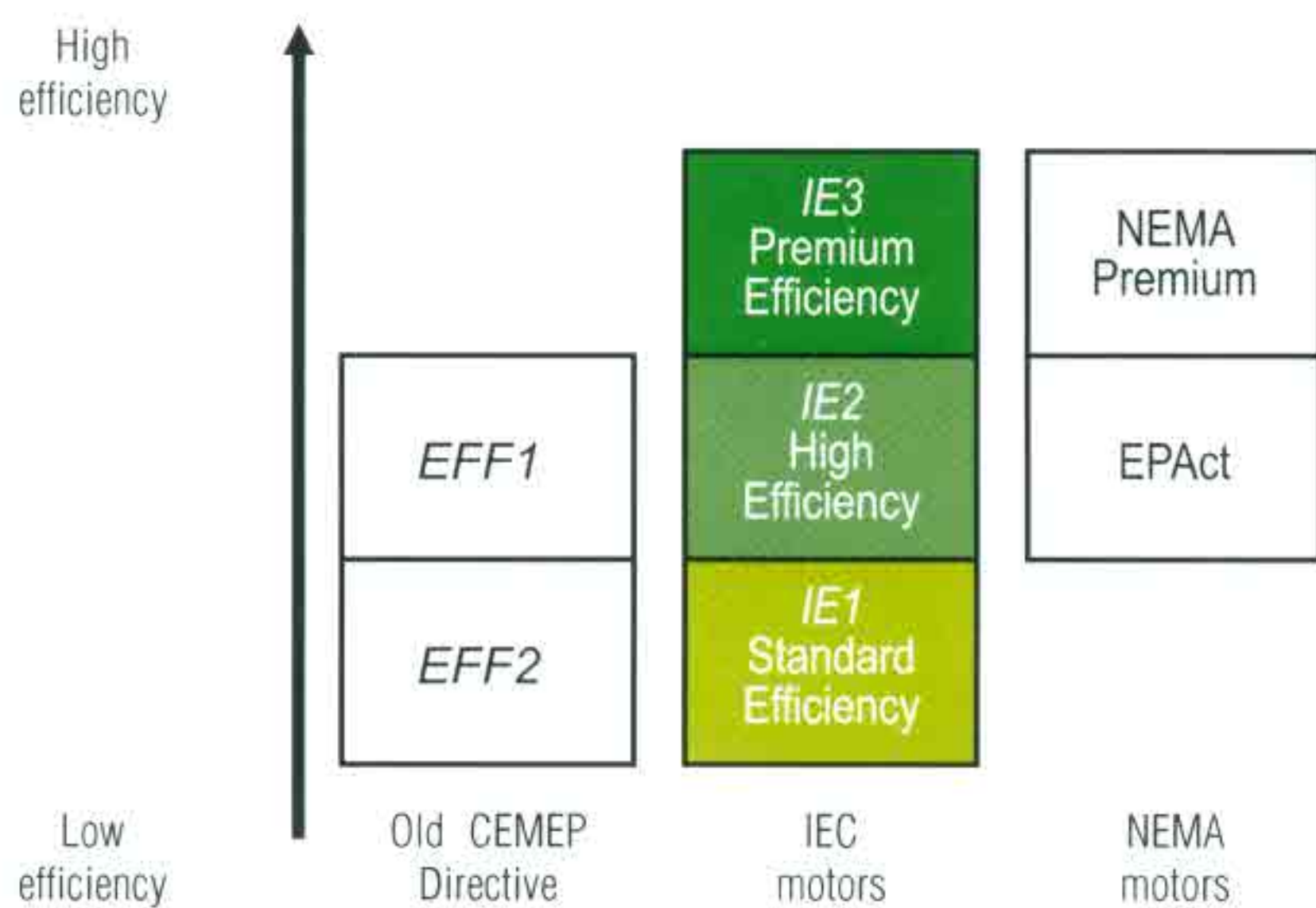

IE Classes - 4 pole

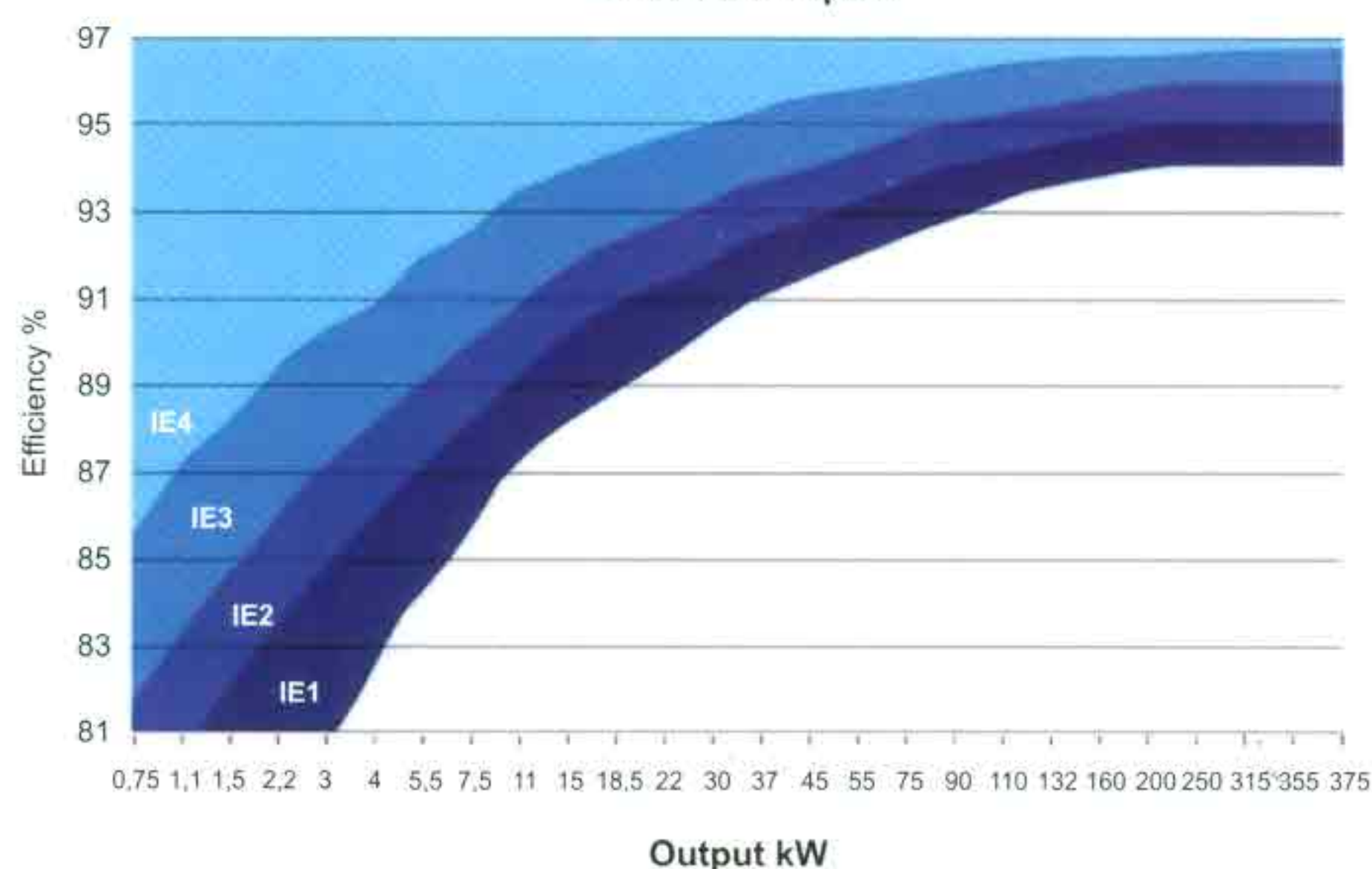

### 2. Why improving motor efficiency is important?

Over 70 % of all electrical energy consumed in industries is used by electric motors. Improving the efficiency of electric motors and the driven equipment can save energy, reduce operating costs, and improve our nation's productivity. Energy efficiency should be a major consideration when you purchase or rewind a motor. The annual energy cost of running a motor is usually many times greater than its initial purchase price. For example, even at the relatively low energy rate of Rs.0.085/kWh, a typical 15 kW continuously running motor uses almost Rs.12,000 worth of electricity annually, about six times its initial purchase price.

### 3. What efficiency values should I use when comparing motors?

When comparing motor efficiencies, be sure to use a consistent measure of efficiency. Nominal efficiency is best. Nominal efficiency is an average value obtained through standardized testing of a population of motors. Minimum guaranteed efficiency, which is based on nominal efficiency, is slightly lower to take into account typical population variations. Minimum guaranteed efficiency is also less accurate, because the value is rounded. Other efficiency ratings, including apparent and calculated, should not be used.

### 4. When should I consider buying an energy-efficient motor?

Energy-efficient motors should be considered in the following circumstances:  
For all new installations

- When purchasing equipment packages, such as compressors, HVAC systems, and pump
- When major modifications are made to facilities or processes
- Instead of rewinding older, standard efficiency units
- To replace oversized and under loaded motors
- As part of a preventive maintenance or energy conservation program.

### 5. Should I rewind a failed motor?

Although failed motors can usually be rewound, it is often worthwhile to replace a damaged motor with a new energy-efficient model to save energy and improve reliability. At the time of calculating operating costs for rewind motors, deduct one efficiency point for motors exceeding 30 kW and two points for smaller motors. Have motors rewound only at CG authorized service centers that use low temperature bake out ovens, high quality materials, and a quality assurance program based on ISO-9000. Ask the repair shop to conduct a core loss or loop test as part of their rewind procedures. Select a new energy-efficient motor under any of the following conditions:

- The motor is less than 30 kW
- The cost of the rewind exceeds 65% of the price of a new motor.
- The motor was rewound before year 2000

### 6. What design factors should I consider when choosing a new motor?

#### Motor size-

Motors should be sized to operate with a load factor between 65% and 100%. The common practice of over sizing results in less efficient motor operation. For example, a motor operating at a 35% load is less efficient than a smaller motor that is matched to the same load. Of course, some situations may require over sizing for peak loads, but in such cases alternative strategies should be considered, such as a correctly sized motor backed up with a pony motor.

#### Operating speed-

Replacement is to done by energy efficient motors with a comparable full load speed for centrifugal load applications (pumps and fans). Induction motors have an operating speed that is slightly lower than their rated synchronous speed. For example, a motor with a synchronous speed of 1500 rpm will typically operate under full load at about 1420 rpm. Operating speed (full-load rpm) is stamped on motor nameplates. The difference between the synchronous speed and the operating speed is called slip. Slip varies with load and the particular motor model. Every pump and fan has a designed speed. Centrifugal pump and fan loads are extremely sensitive to speed variations; an increase of just 5 rpm can significantly affect the pump or fan operation, leading to increased flow, reduced efficiency, and increased energy consumption. Whenever a pump or fan motor is replaced, be sure to select a model with a full-load rpm rating equal to or less than that of the motor being replaced.

#### Inrush current-

Avoid overloading circuits. Energy-efficient motors feature low electrical resistance and thus exhibit higher inrush currents than standard models. The inrush current duration is too short to trip thermal protection devices, but energy-efficient motors equipped with magnetic circuit protectors can sometimes experience nuisance starting trips.

### 7. How to calculate energy savings and payback period?

5.5 kW 4 pole standard IE1 motor is having efficiency 84.7 %. Where as Apex Series IE2 has 87.7 %

$$\begin{aligned} \text{Energy Savings (S)}^* &= W \times L \times C \times N \times (100/E_s - 100/E_e) \\ &= 5.5 \times 1 \times 5.8 \times 4800 \times (100/84.7 - 100/87.5) \\ &= 5785 \text{ ₹ per year} \end{aligned}$$

$$\begin{aligned} \text{Payback Period (P)}^* &= C_e/S \times 12 \\ &= 3.6 \text{ months} \end{aligned}$$

W-Motor Rating in kW  
L-% load (1 for rated kW loading)  
C-Electricity Cost ₹/kWh  
N-Number of working Hours per year

Ee-Efficiency of IE2 motor  
Es- Efficiency of standard IE1 motor  
Ce-Cost of IE2 motor- Cost of IE1 motor  
i.e.(12865-11111=1754 ₹)

\* This may vary with the application and working hours